

E1130-0026

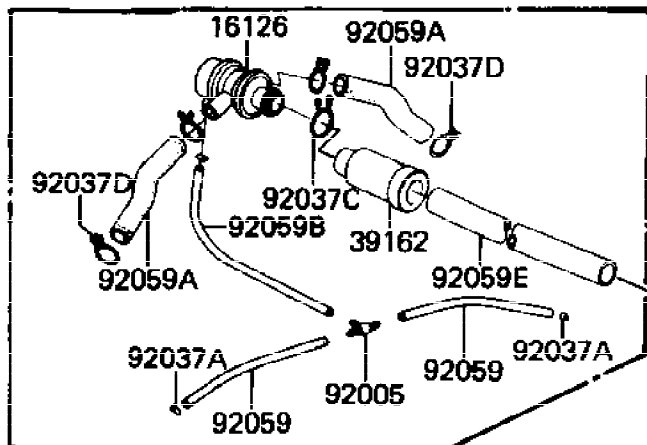

FRONT

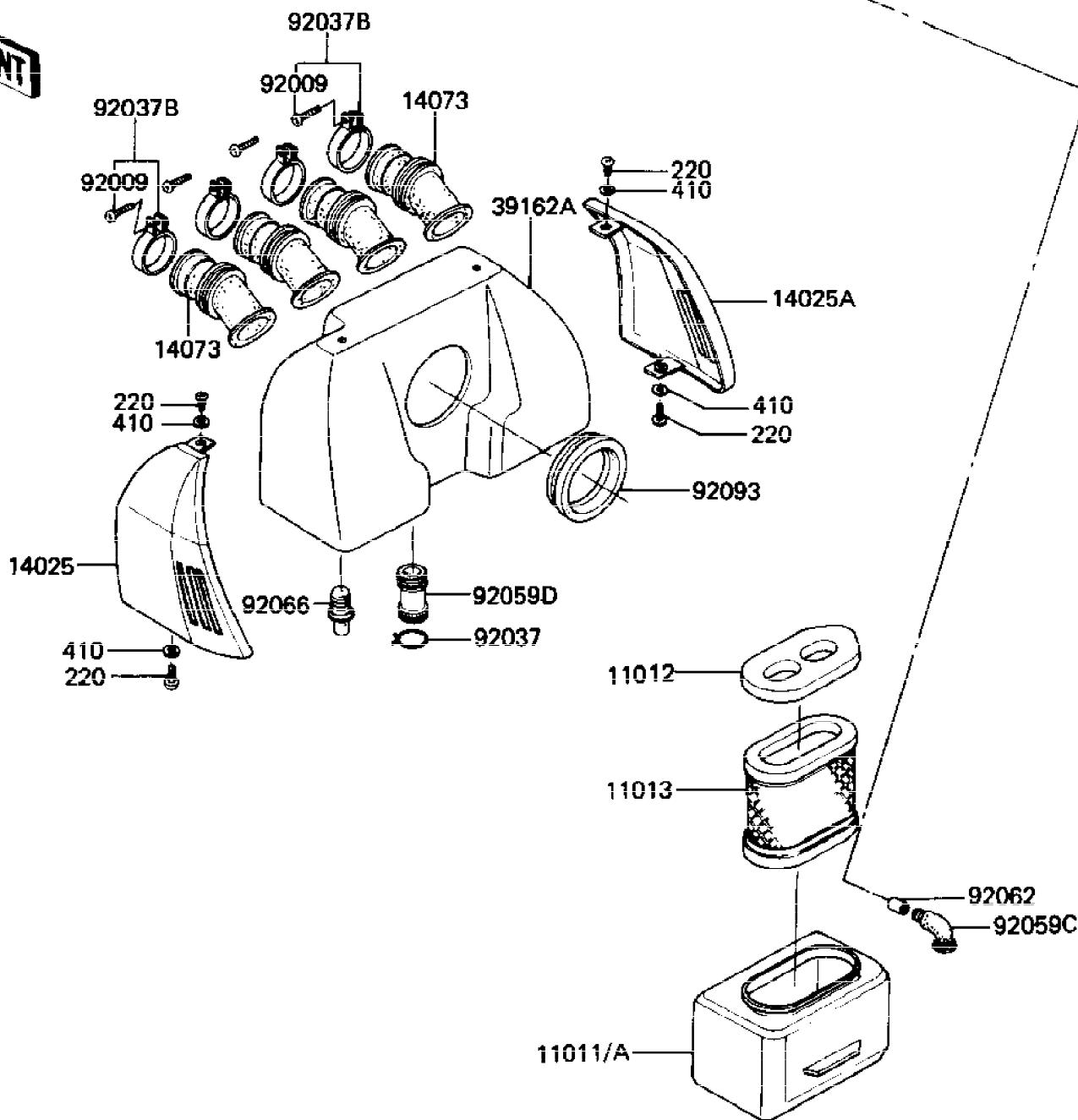

Ref #	Part Number	Qty	Description
11011	11011-1070	1	CASE-AIR FILTER US
11011A	11011-1074	1	CASE-AIR FILTER CN
11012	11012-1152	1	CAP,AIR FILTER
11013	11013-1040	1	ELEMENT,AIR CLNR
14025	14025-1319	1	COVER,AIR FILTER,LH
14025A	14025-1320	1	COVER,AIR FILTER,RH
14073	14073-1054	4	DUCT,AIR FILTER
16126	16126-1014	1	VALVE ASSY,AIR SWITCH US
39162	39162-1003	1	SILENCER US
39162A	39162-1004	1	SILENCER-INTAKE
92005	92005-1017	1	FITTING,TUBE US
92009	92011-037	4	SCREW,PAN HEAD
92037	92037-028	1	CLAMP BREATHER PIPE
92037A	92037-072	3	CLAMP-PIPE US
92037B	92037-077	4	CLAMP,HOLDER
92037C	92037-1076	1	CLAMP US
92037D	92037-213	4	CLAMP,BREATHER TUBE US
92059	92059-1131	2	TUBE,4X9X110 US
92059A	92059-1155	2	TUBE,14X20X89 US
92059B	92059-1162	1	TUBE,VACUUM,LONG US
92059C	92059-1163	1	TUBE,AIR FILTER,BEND US
92059D	92059-1164	1	TUBE,AIR FILTER BLEED
92059E	92059-1177	1	TUBE,AIR FILTER,L=510 US
92062	92062-1019	1	NOZZLE,AIR FILTER US
92066	92066-1048	1	PLUG
92093	92093-1055	1	SEAL,INTAKE SILENCER
220	220B0508	4	SCREW PAN HEAD 5X8
410	410B0500	4	WASHER PLAIN 5MM

E1130-0070

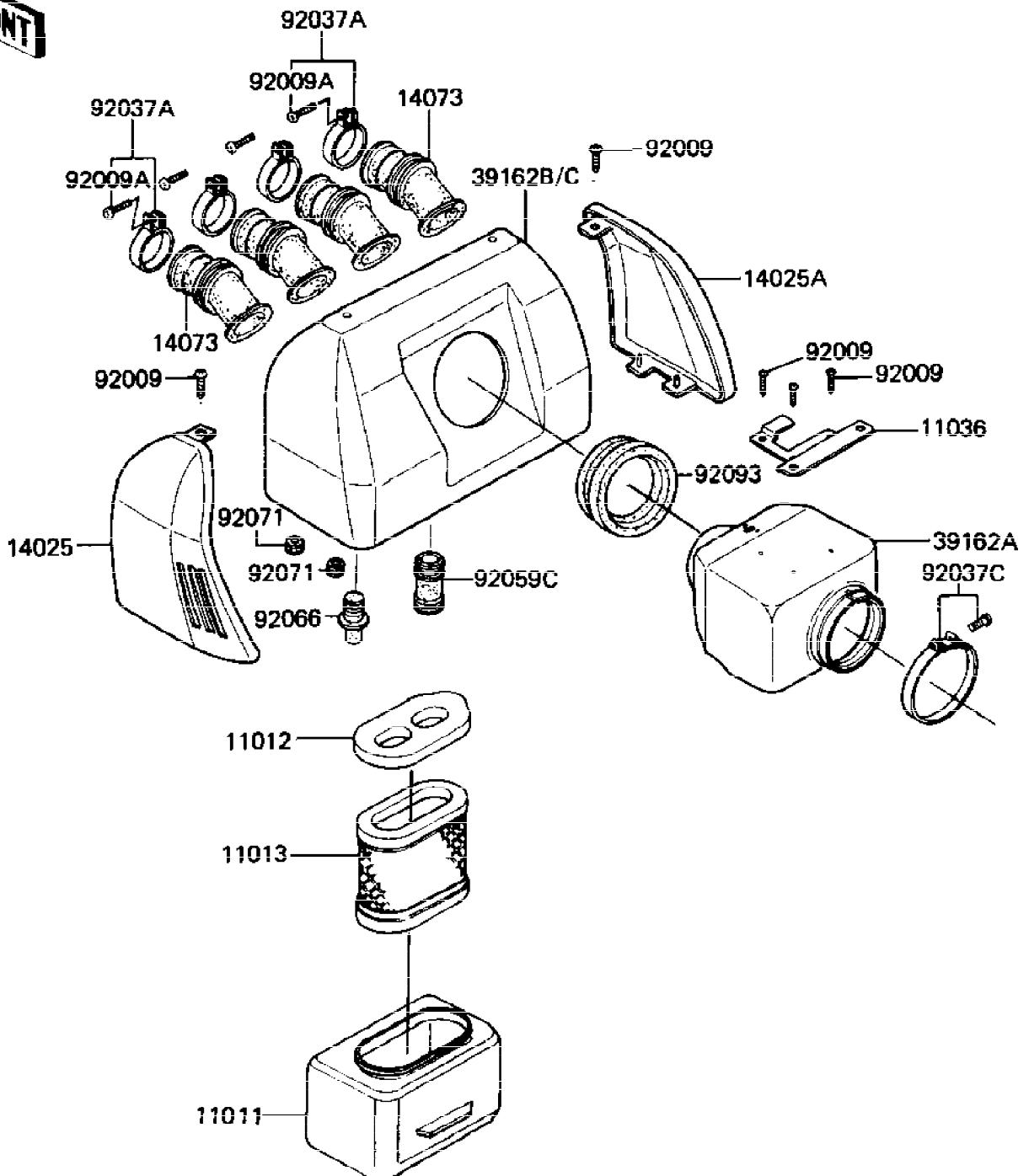
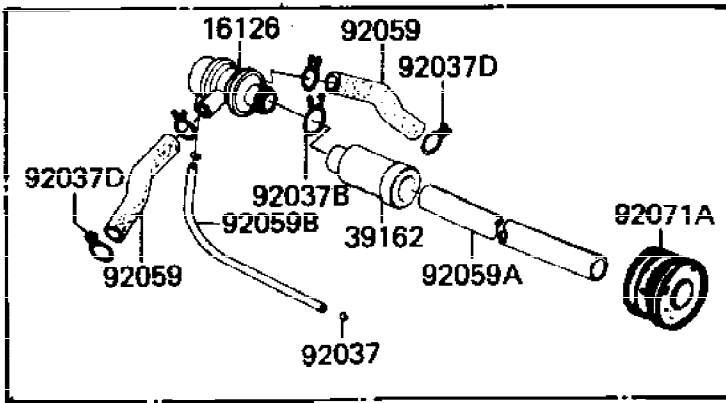

Ref #	Part Number	Qty	Description
11011	11011-1074	1	CASE-AIR FILTER
11012	11012-1152	1	CAP,AIR FILTER
11013	11013-1040	1	ELEMENT,AIR CLNR
11036	11036-1391	1	BRACKET-A,INTAKE SILE
14025	14025-1460	1	COVER,INT SILENCER,LH
14025A	14025-1461	1	COVER,INT SILENCER,RH
14073	14073-1054	4	DUCT,AIR FILTER
16126	16126-1014	1	VALVE ASSY,AIR SWITCH US
39162	39162-1003	1	SILENCER US
39162A	39162-1005	1	SILENCER-INTAKE
39162B	39162-1006	1	SILENCER-INTAKE US
39162C	39162-1007	1	SILENCER-INTAKE (Canada) CN
92009	92009-1138	5	SCREW,TAPPING,5X12,BL
92009A	92011-037	4	SCREW,PAN HEAD
92037	92037-072	2	CLAMP-PIPE US
92037A	92037-077	4	CLAMP,HOLDER
92037B	92037-1076	1	CLAMP US
92037C	92037-129	1	CLAMP,AIR CLEANER
92037D	92037-213	4	CLAMP,BREATHING TUBE US
92059	92059-1155	2	TUBE,14X20X89 US
92059A	92059-1161	1	TUBE,14X20X320 US
92059B	92059-1162	1	TUBE,VACUUM,LONG US
92059C	92059-1164	1	TUBE,AIR FILTER BLEED
92066	92066-1048	1	PLUG
92071	92071-1041	4	GROMMET,ID=4
92071A	92071-1042	1	GROMMET,AIR FILTER US
92093	92093-1055	1	SEAL,INTAKE SILENCER

F2132-0026

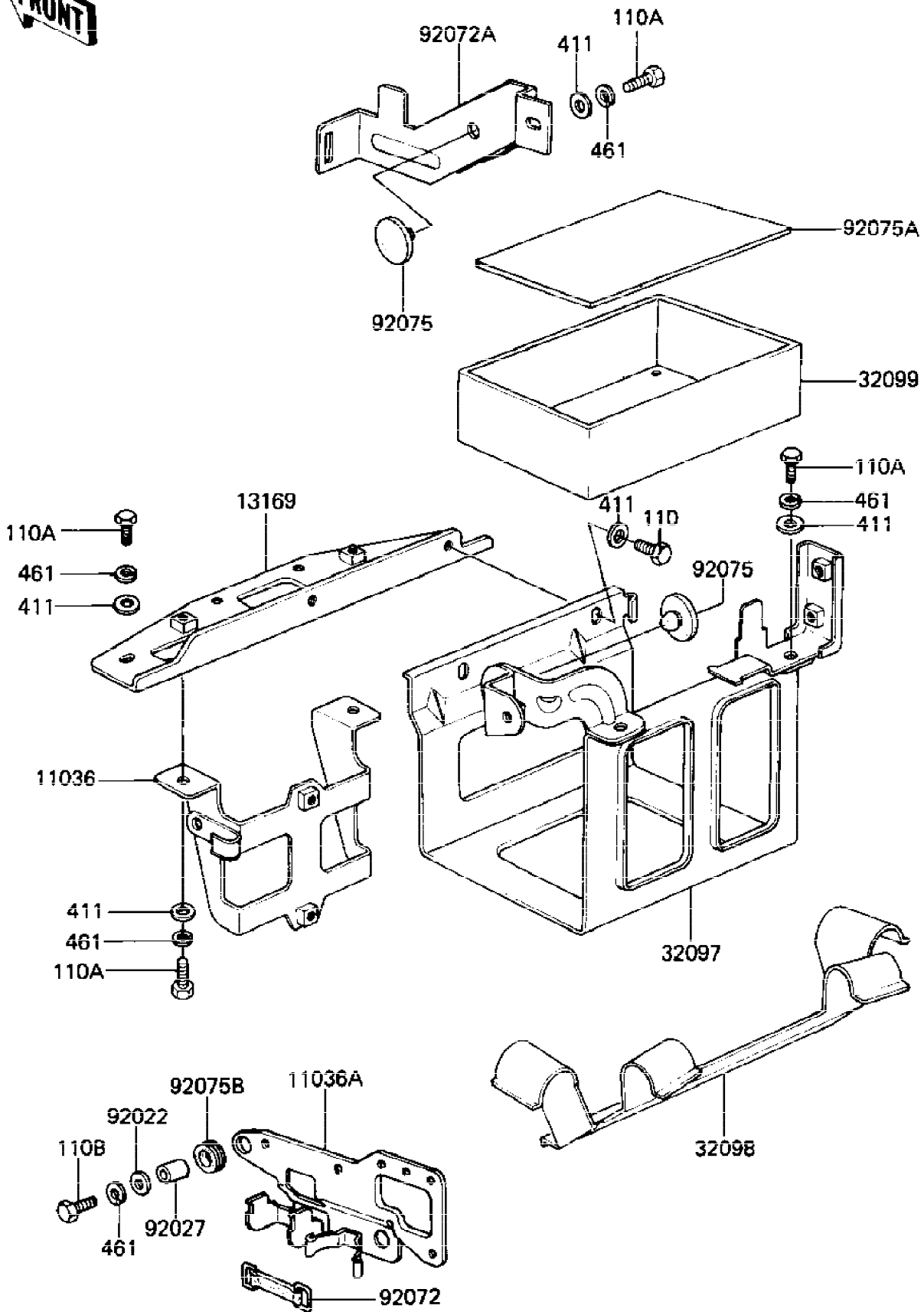

Ref #	Part Number	Qty	Description
11036	11036-1061	1	BRACKET-A,REGULATOR
11036A	11036-1064	1	BRACKET-A,FUEL FILTER
13169	13169-1395	1	PLATE,BATTERY CASE,FR
32097	32097-1037	1	CASE-BATTERY
32098	32098-1017	1	CASE-TOOL
32099	32099-1009	1	CASE
92022	92022-125	2	WASHER 6.5X20X1.6T
92027	92027-165	2	COLLAR
92072	92072-1017	1	BAND,AIR CLEANER FITT
92072A	92072-158	1	UNAVAILABLE IN PRICE BOOK
92075	92075-078	2	DAMPER RUBBER
92075A	92075-1143	1	DAMPER,BATTERY
92075B	92075-149	2	DAMPER RUBBER
110	112G0612	2	BOLT-UPSET,6X12
110A	112B0614	7	BOLT-UPSET 6X14
110B	112G0620	2	BOLT-UPSET,6X20
411	411B0600	9	WASHER PLAIN 6MM
461	461F0600	9	WASHER SPRING 6MM

F2260-0075

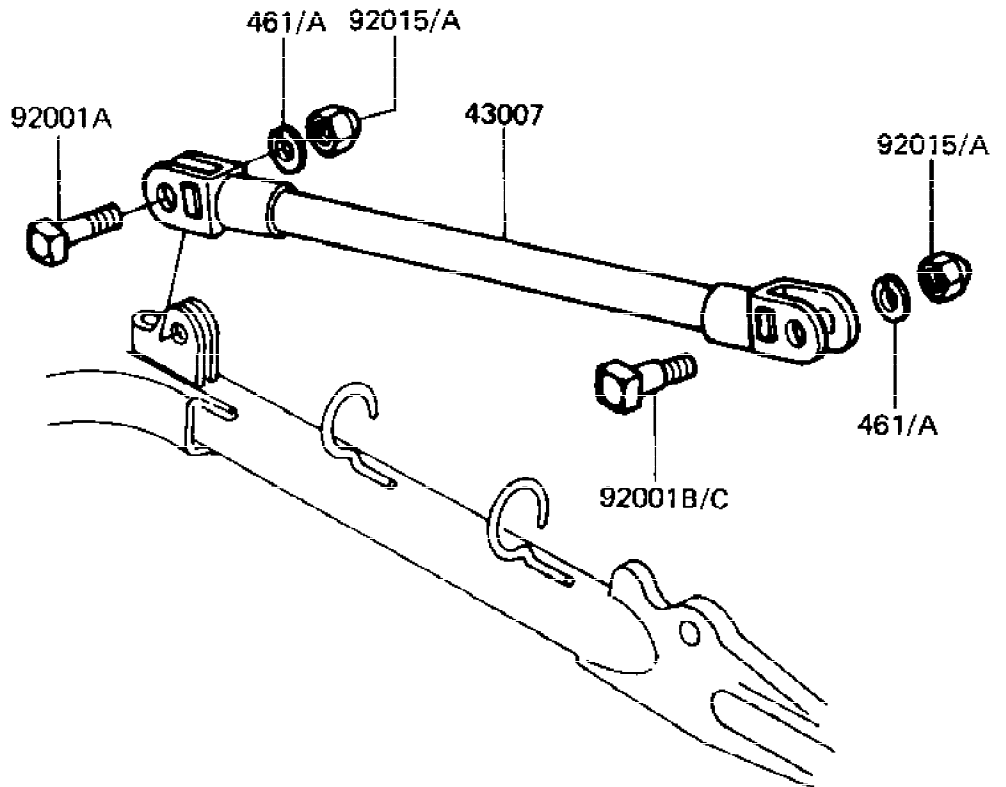
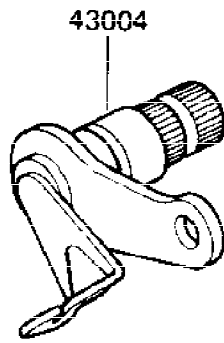
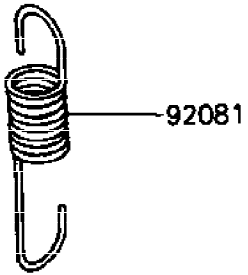
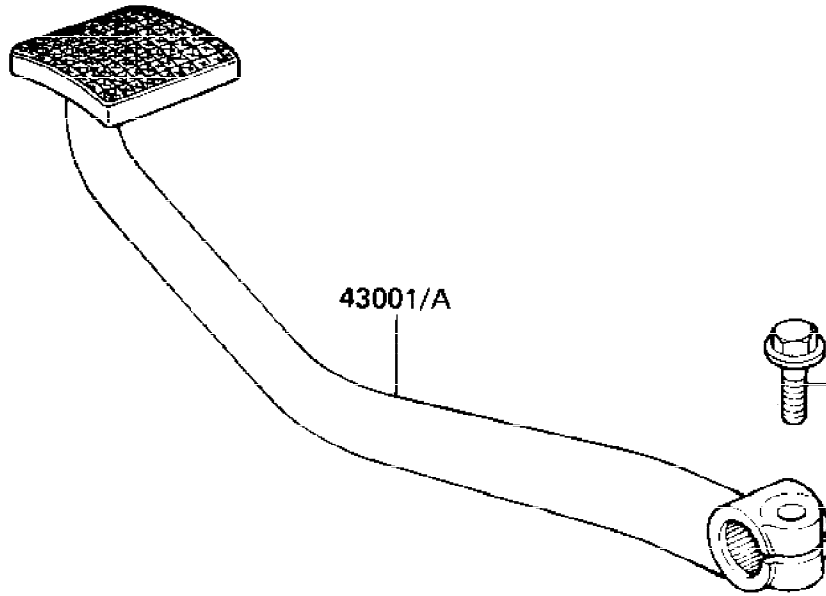

Ref #	Part Number	Qty	Description
43001	43001-1071	1	LEVER-BRAKE,PEDAL (SUBSTITUTES 43001-1071 )
43001A	43001-1071	1	LEVER-BRAKE,PEDAL
43004	43004-1026	1	SHAFT-BRAKE
43007	43007-1015	1	TORQUE ROD,REAR BRAKE
92001	130G0825	1	BOLT-FLANGED,8X25
92001A	92001-1208	1	BOLT,TORQUE ROD FRONT
92001B	92001-1307	1	BOLT,SQUARE HEAD
92001C	92001-1646	1	BOLT,10X37
92015	92015-1189	2	NUT,LOCK,10MM,BLACK
92015A	92015-1429	2	NUT,10MM
92081	92081-1296	1	SPRING
131	131J0825	1	BOLT-FLANGED,8X25,BLA
461	461F1000	2	WASHER SPRING 10MM
461A	461K1000	2	WASHER-SPRING,10MM





Ref #	Part Number	Qty	Description
11009	11060-1074	1	GASKET,OIL PAN
11009A	92065-097	1	GASKET,DRIN PLUG
14070	14070-1008	1	BODY-BREATHER
14070A	14070-1010	1	BODY-BREATHER,BLACK
27010	27010-1067	1	SWITCH,OIL LEVEL
49034	49034-5020	1	PAN-OIL
49034A	49034-5013	1	PAN-OIL,F.BLACK
92001	92001-1183	1	PLUG,OIL DRAIN
92001A	92001-1526	1	BOLT,8X72,BLACK
92001B	92003-107	1	BOLT,HEX HEAD,8X72
92037	21126-008	1	CLAMP,WIRING HARNESS
92055	92055-052	2	"O" RING,91MM
92066	92066-1174	1	PLUG,OIL DRAIN,12X15
130	130B0616	2	BOLT-FLANGED,6X16
130A	130G0625	13	BOLT,FLANGED,6X25
130B	130H0635	3	BOLT,FLANGED,6X35
130C	130G0645	1	BOLT,FLANGED,6X45
670	670B1508	1	"O" RING,8MM
670A	670B2022	1	"O" RING,22MM
671	671E2525	1	O RING,25MM

F2540-0106

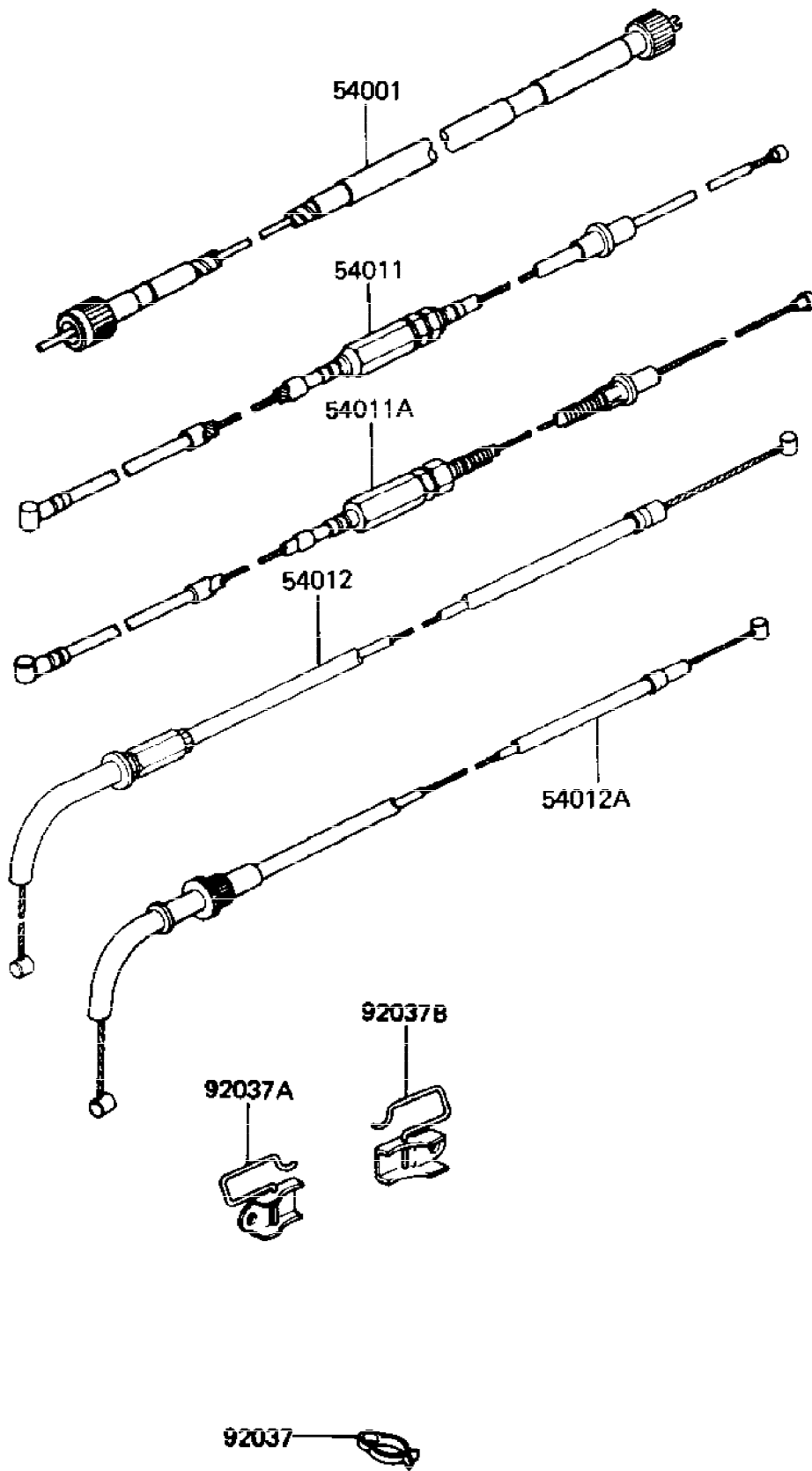

Ref #	Part Number	Qty	Description
54001	54001-1014	1	CABLE,SPEEDOMETER
54011	54011-1136	1	CABLE-CLUTCH
54011A	54011-1101	1	CABLE-CLUTCH
54012	54012-1111	1	CABLE-THROTTLE (SUBSTITUTES 54012-1111 )
54012A	54012-1111	1	CABLE-THROTTLE
92037	92037-093	1	CLAMP,CABLE
92037A	92037-1250	1	CLAMP
92037B	92037-1251	1	CLAMP

E1230-0023

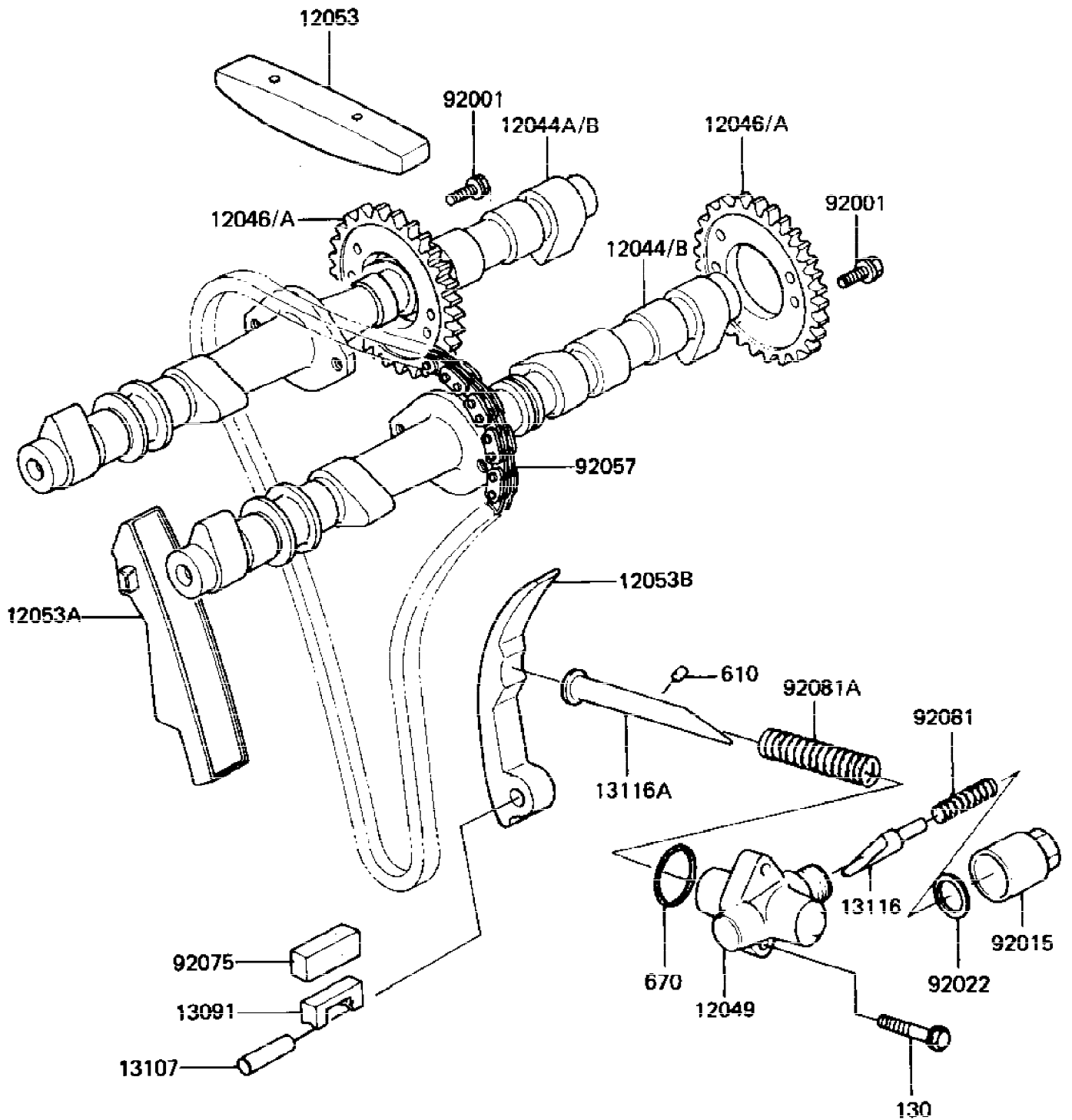

Ref #	Part Number	Qty	Description
12044	12044-1031	1	CAMSHAFT-VALVE,INLET
12044A	12044-1036	1	CAMSHAFT-VALVE,EXHAUS
12044B	12044-1037	2	CAMSHAFT-VALVE
12046	12046-1025	2	SPROCKET,CAMSHAFT EXH
12046A	12046-1033	2	SPROCKET,CAMSHAFT,42T
12049	12049-1009	1	TENSIONER,CAM CHAIN
12053	12053-1018	1	GUIDE,CAM CHAIN,HEAD
12053A	12053-1048	1	GUIDE-CHAIN,CAM,FR
12053B	12053-1049	1	GUIDE-CHAIN,CAM,RR
13091	13091-1084	1	HOLDER,CAM CHAIN GUID
13107	13107-1020	1	SHAFT,8X28
13116	13116-1012	1	ROD,PUSH,CAM CHAIN
13116A	13116-1038	1	ROD-PUSH,TENSIONER
92001	92003-208	4	BOLT,SPROCKET FITTING
92015	92015-1100	1	CAP,TENSIONER,18M/M
92022	92022-1175	1	WASHER,18.3X24X1.4T
92057	92057-1052	1	CHAIN,CAMSHAFT,75-010
92075	92075-1270	1	DAMPER
92081	92081-1302	1	SPRING,TENSIONER
92081A	92081-1380	1	SPRING,TENSIONER
130	130G0625	2	BOLT,FLANGED,6X25
610	610A0408	1	PIN DOWEL 4X8
670	670E2022	1	"O" RING,22M/M

F2760-0142

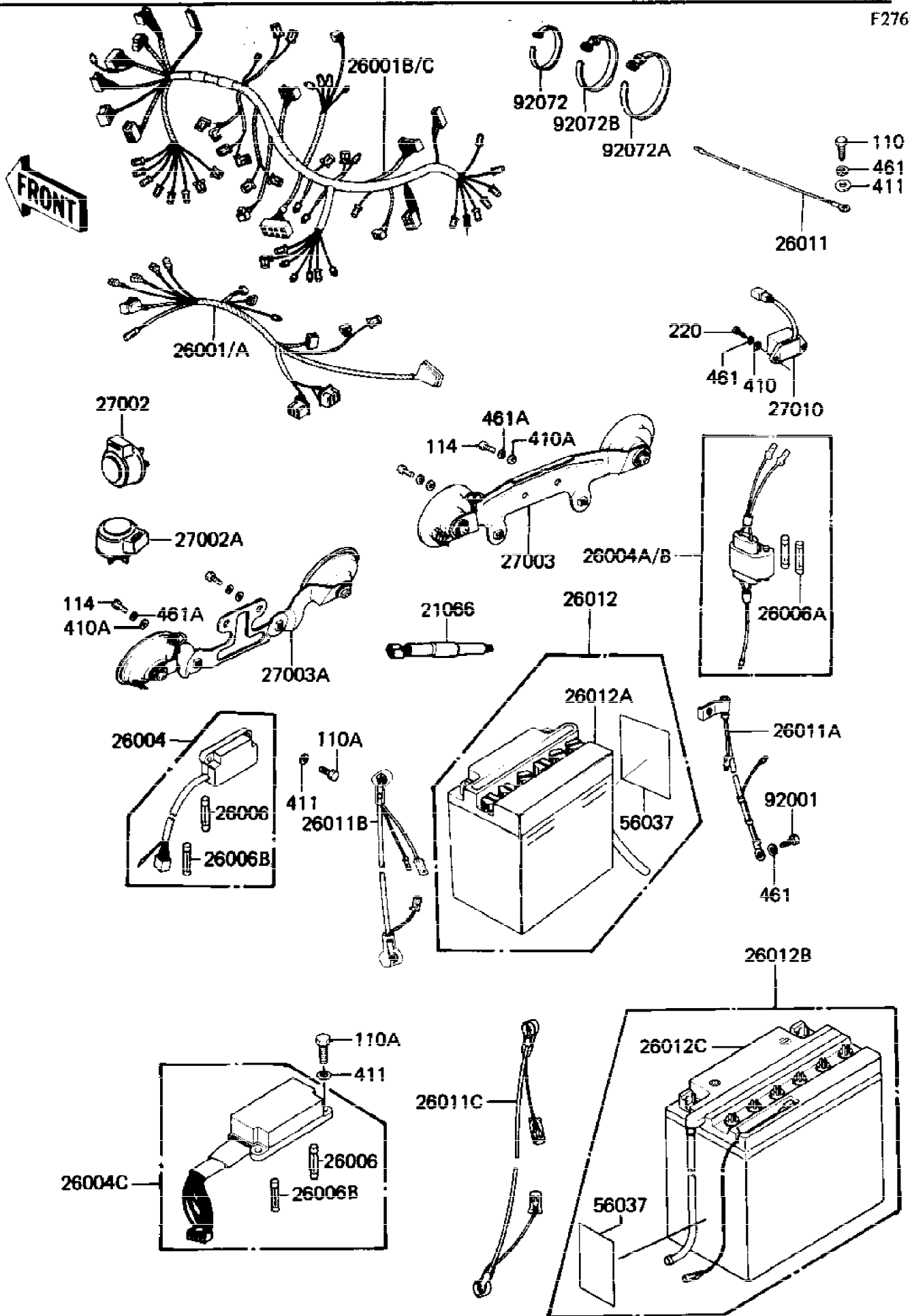

Ref #	Part Number	Qty	Description
21066	21066-026	1	REGULATOR
26001	26001-1263	1	HARNESS,CONTROL UNIT
26001A	26001-1328	1	HARNESS,ELECTRIC CONT
26001B	26001-1354	1	HARNESS,MAIN
26001C	26001-1366	1	HARNESS,MAIN
26004	26004-1011	1	FUSE-ASSY
26004A	26004-1014	1	FUSE-ASSY,ACCESSORY
26004B	26004-1016	1	FUSE-ASSY,ACCESSORY
26004C	26004-1017	1	FUSE-ASSY
26006	26006-003	5	FUSE 10A
26006A	26006-1002	3	FUSE,10A,L=30M/M
26006B	26006-1005	2	FUSE,30A,L=25M/M
26011	26011-1069	1	WIRE,LEAD
26011A	26011-1119	1	WIRE-LEAD,BATTERY,(-)
26011B	26011-1126	1	WIRE-LEAD,STARTER MTR
26011C	26011-1154	1	WIRE-LEAD,STRTR MOTOR
26012	26012-1013	1	FB BAT 12N16-3B US
26012A	26012-1015	1	BATT 12N16-3B CN
26012B	26012-1053	1	FB BAT 12N16-3BSENSOR US
26012C	26012-1054	1	26012-1013 (Canada) CN
27002	27002-011	1	RELAY-TURN SIGNAL
27002A	27002-016	1	RELAY,TURN SIGNAL
27003	27003-1054	1	HORN
27003A	27003-1143	1	HORN,DOUBLE
27010	27010-1024	1	SWITCH,RESERVE LIGHTI
56037	56040-1036	1	LABEL-WARNING,BATTERY US
92001	92001-137	1	BOLT,HEX HEAD,6MM
92072	92072-031	7	BAND,MIDDLE
92072A	92072-032	2	BAND,LONG
92072B	92072-056	2	BAND,WIRING HARNESS
110	112G0612	1	BOLT-UPSET,6X12
110A	112B0622	2	BOLT 6X22
114	115C0816	2	BOLT-SMALL,8X16,BLACK
220	220B0620	2	SCREW PAN HEAD 6X20
410	410B0600	2	WASHER PLAIN 6MM
410A	92022-1554	2	WASHER,PLAIN,8MM
411	411B0600	3	WASHER PLAIN 6MM
461	461F0600	6	WASHER SPRING 6MM
461A	461K0800	2	WASHER-SPRING,8MM,BLA



E1350-0022

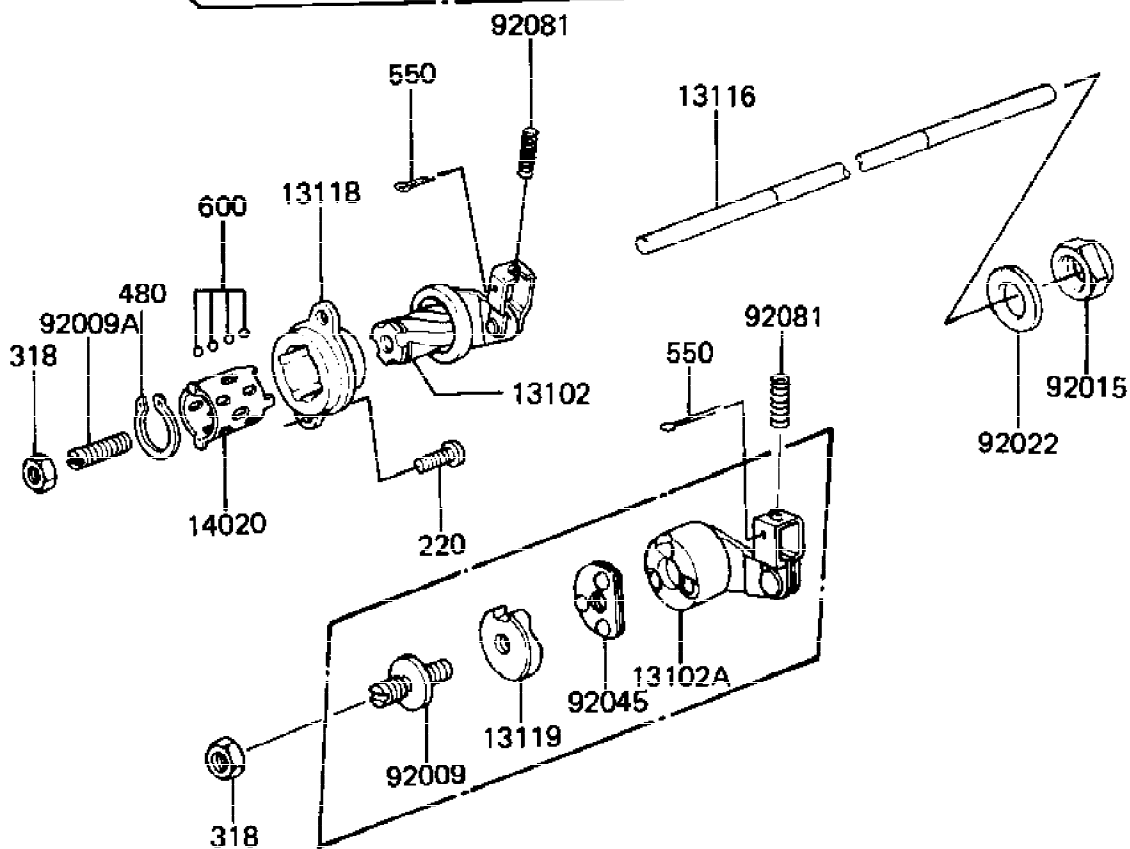
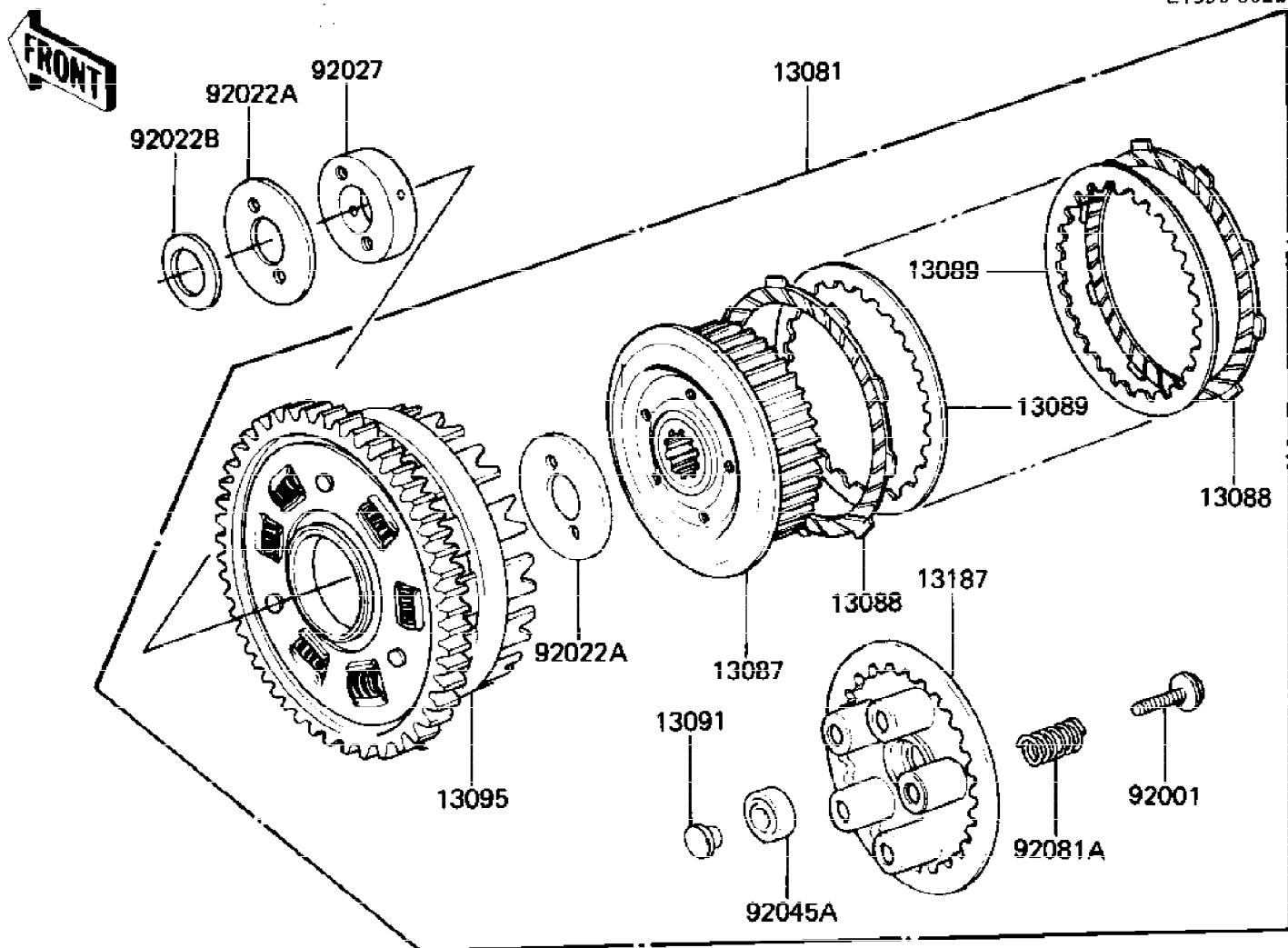

Ref #	Part Number	Qty	Description
13081	13081-1057	1	CLUTCH-ASSY
13087	13087-1015	1	HUB-CLUTCH
13088	13088-1013	9	PLATE-FRICTION
13089	13089-1004	8	PLATE,CLUTCH,STEEL
13091	13091-1085	1	HOLDER
13095	13095-1037	1	HOUSING-COMP-CLUTCH
13102	13102-019	1	INNER,CLUTCH RELEASE
13102A	13102-1012	1	RELEASE-COMP-CLUTCH
13116	13116-1033	1	ROD-PUSH
13118	13118-011	1	OUTER,CLUTCH RELEASE
13119	13119-1003	1	CAM,RELEASE,CLUTCH
13187	13187-1006	1	PLATE-CLUTCH OPERATIN
14020	13197-004	1	RETAINER
92001	92001-1066	5	BOLT,CLUTCH SPR FITT
92009	92009-1009	1	SCREW,SLOTTED,8M/M
92009A	92014-014	1	SCREW,SLOTTED,8X25
92015	92015-1555	1	NUT,20MM
92022	92022-1116	1	WASHER,PLAIN,2.3X20.3
92022A	92022-1221	2	WASHER,CLUTCH THRUST
92022B	92022-1223	1	WASHER
92027	92027-1284	1	COLLAR
92045	92045-1001	1	BEARING,BALL,CLUTCH
92045A	92045-1235	1	BEARING-BALL
92081	92081-069	1	SPRING-CLUTCH RELEASE
92081A	92081-1033	5	SPRING,CLUTCH
220	220B0616	2	SCREW PAN HEAD 6X16
318	318B0800	1	NUT 8MM
480	480J1500	1	CIRCLIP 15MM
550	550D1615	1	PIN COTTER 1.6X15
600	600A0400	11	BALL,STEEL,1/8"

E1411-0052

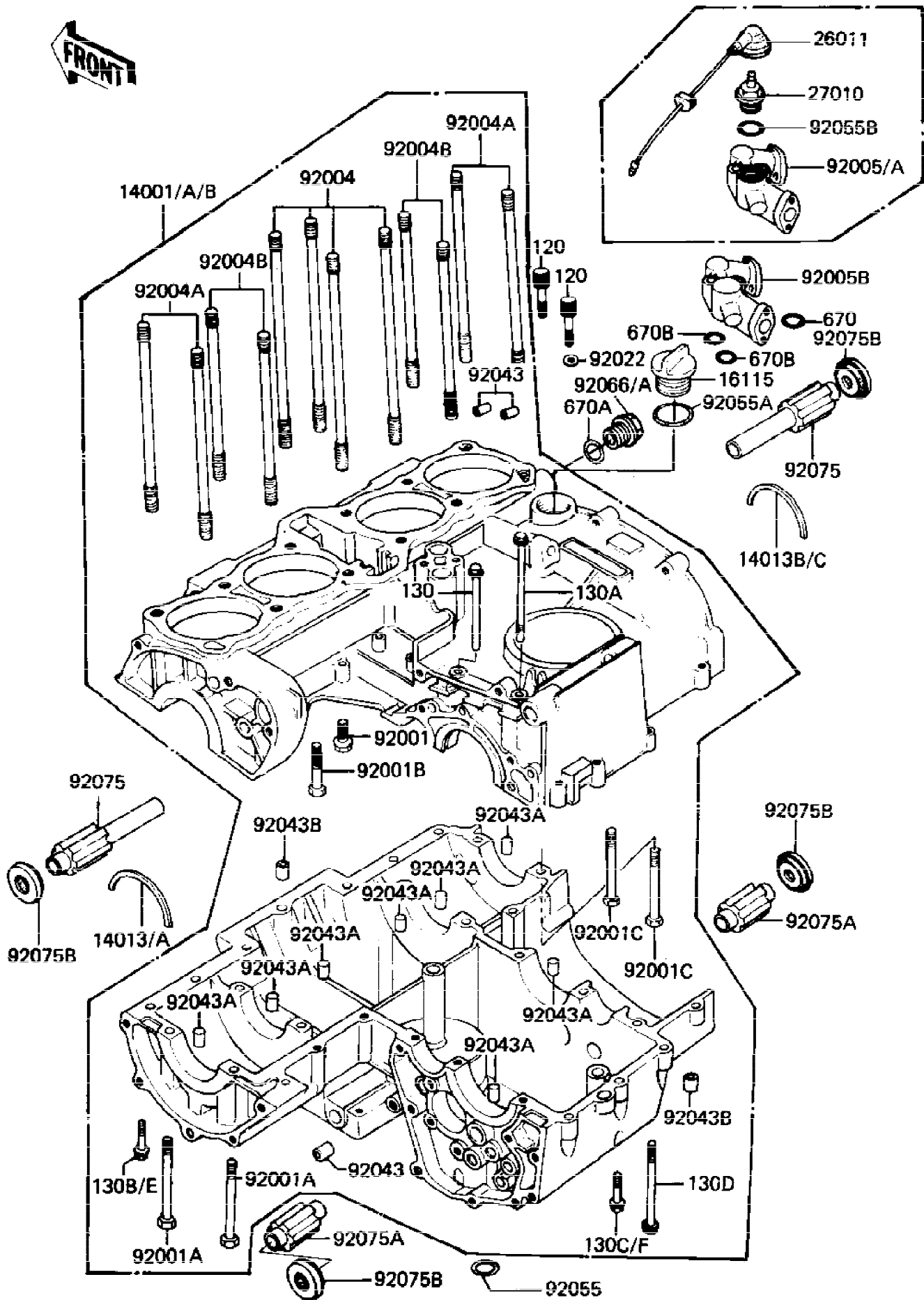

Ref #	Part Number	Qty	Description
14001	14001-5112	1	SET-CRANKCASE,F.BLACK (SUBSTITUTES 14001-5098 )
14001A	14001-5112	1	SET-CRANKCASE,F.BLACK
14001B	14001-5112	1	SET-CRANKCASE,F.BLACK
14013	14013-013	1	RING-BEARING SET
14013A	14013-1004	1	RING,POSITION
14013B	14013-1005	1	RING-POSITION
14013C	14013-1006	1	RING-POSITION
16115	16115-1009	1	CAP-OIL FILLER
26011	26011-1129	1	WIRE-LEAD,OIL SWITCH
27010	27010-1013	1	SWITCH,OIL PRESSURE
92001	92001-1349	2	BOLT,FLANGED,8X16
92001	92001-1349	1	BOLT,FLANGED,8X16
92001A	130P0895	2	BOLT-FLANGED,8X95
92001B	92003-107	8	BOLT,HEX HEAD,8X72
92001C	92003-108	2	BOLT,HEX HEAD,8X81
92004	92004-1002	4	STUD,10X190
92004A	92004-1003	4	STUD,10X158
92004B	92004-1004	4	STUD,10X133
92005	92005-1055	1	FITTING,OIL COOLER (SUBSTITUTES 92005-1043 )
92005A	92005-1055	1	FITTING,OIL COOLER ( KZT10BE001584 - )
92005B	92005-1101	1	FITTING,OIL COOLER
92022	92022-1086	1	WASHER
92043	92042-007	6	PIN-DOWEL
92043A	92042-016	10	PIN DOWEL 6MM
92043B	92043-1037	4	PIN,DOWEL,10X8.2X14
92055	92055-048	1	O RING,0.D=18MM
92055A	92055-049	1	"O" RING,31MM
92055B	92055-055	1	"O" RING
92066	92066-021	1	PLUG
92066A	92066-1098	1	PLUG,14X12,F.BLACK
92075	92075-1272	2	DAMPER
92075A	92075-1273	2	DAMPER
92075B	92075-1274	4	DAMPER
120	120P0840	2	BOLT-SOCKET,8X40
130	130H06100	1	UNAVAILABLE IN PRICE BOOK
130A	130G06115	1	BOLT-FLANGED,6X115
130B	130G0640	6	BOLT,FLANGED,6X40
130B	130G0640	1	BOLT,FLANGED,6X40
130C	130G0655	2	BOLT,FLANGED,6X55
130C	130G0655	1	BOLT,FLANGED,6X55
130D	130G0695	3	BOLT-FLANGED,6X95
130E	130J0640	2	BOLT-FLANGED,6X40,BLA
130F	130J0655	1	BOLT-FLANGED,6X55,BLA
670	670B1509	1	"O" RING,9MM
670A	670B2015	1	"O" RING,15MM
670B	670B2018	2	"O" RING,18MM

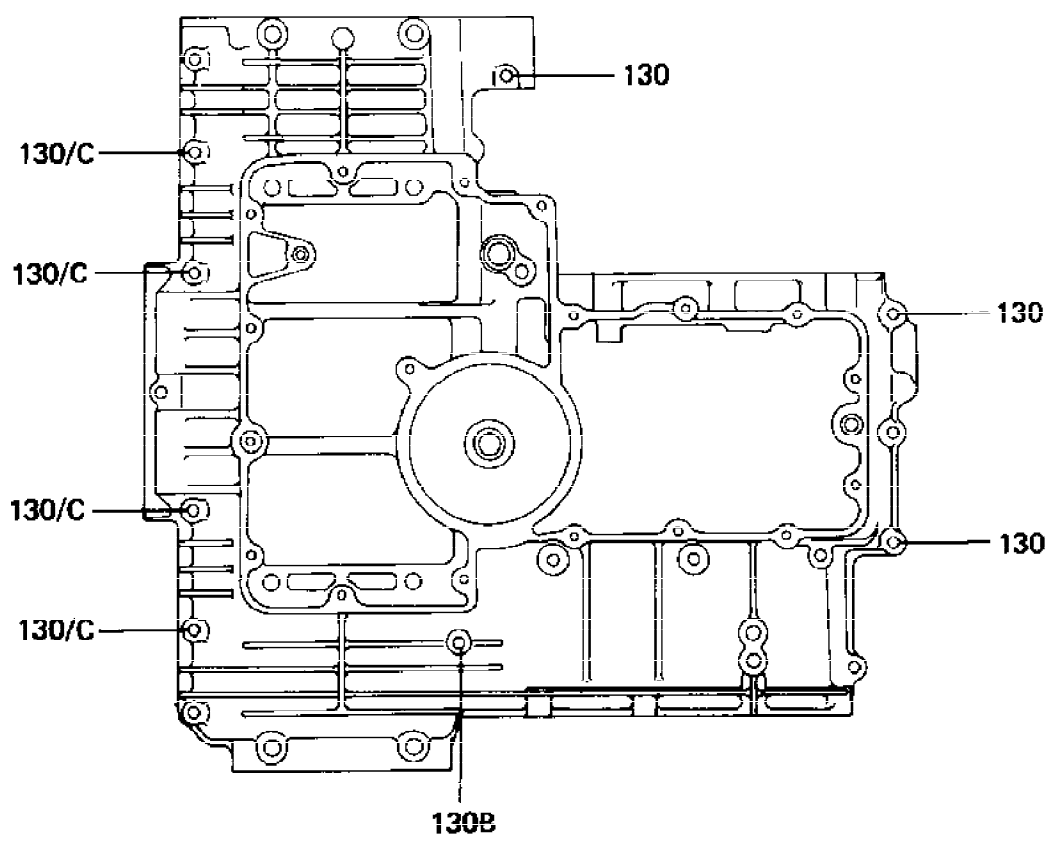
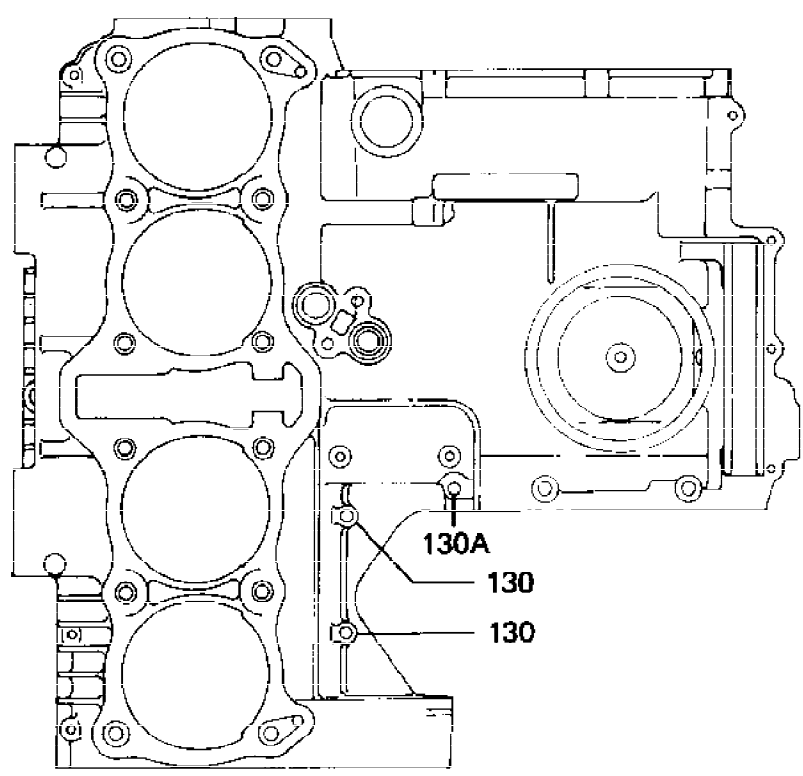

Ref #	Part Number	Qty	Description
130	130G0640	9	BOLT,FLANGED,6X40
130	130G0640	5	BOLT,FLANGED,6X40
130A	130G0650	1	BOLT-FLANGED,6X50
130B	130G0695	1	BOLT-FLANGED,6X95
130C	130J0640	4	BOLT-FLANGED,6X40,BLA

E1320-0008

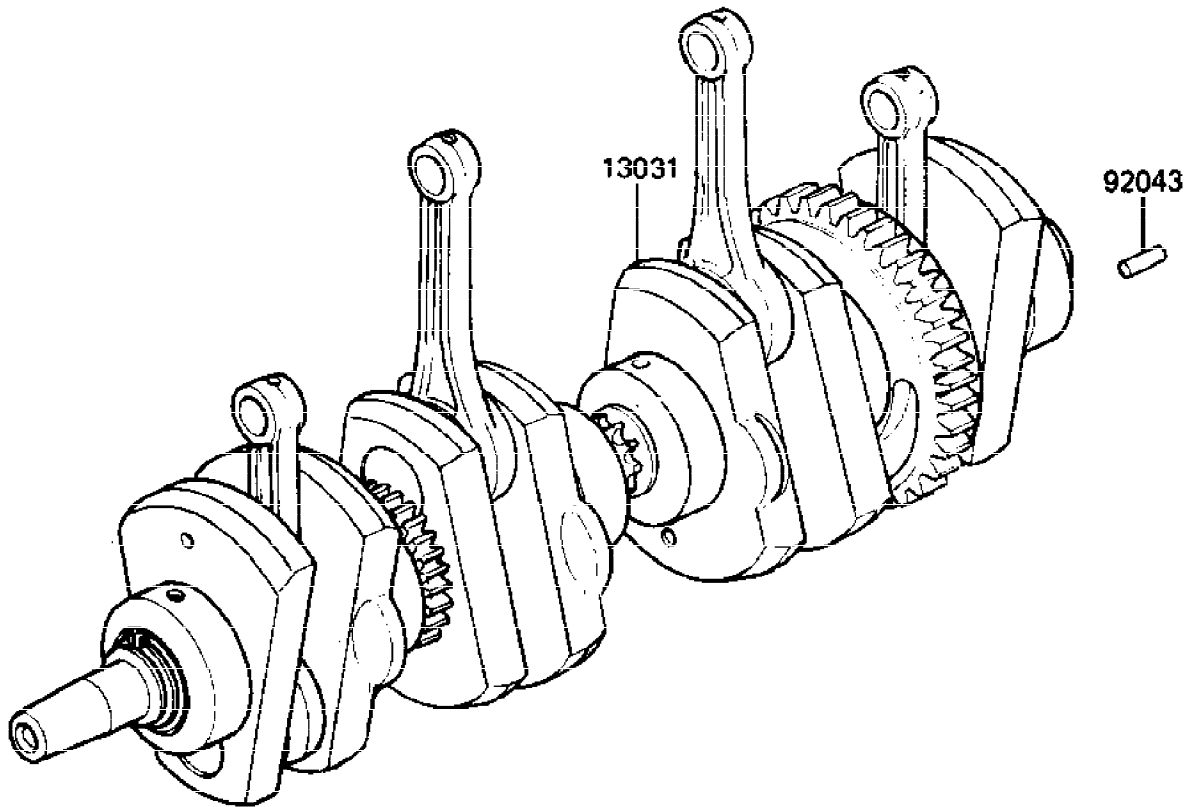

Ref #	Part Number	Qty	Description
13031	13031-1046	1	CRANKSHAFT-COMP
92043	555A0408	1	PIN-SPRING,4X8





Ref #	Part Number	Qty	Description
11004	11004-1105	2	GASKET-HEAD,CYLINDER
11008	11008-1017	1	HEAD-COMP-CYLINDER US
11008A	11008-1018	1	HEAD-COMP-CYLINDER (Canada) CN
13034	13034-030	16	BUSHING,CAMSHAFT
16065	16065-1037	4	HOLDER,THROTTLE
49002	12013-009	4	GUIDE,INLET VALVE
49002A	49002-1002	4	GUIDE,EXHAUST VALVE
92001	92003-092	2	BOLT,HEX HEAD,6X45
92001A	92002-1881	16	BOLT,6X43
92004	92004-1069	8	STUD,8X30
92009	92011-037	4	SCREW,PAN HEAD
92015	92015-076	12	NUT,CYLINDER HEAD
92022	92022-1005	4	WASHER,10.5X22X1.6
92033	92036-023	8	CIRCLIP-VALVE
92037	92037-077	4	CLAMP,HOLDER
92043	92042-007	8	PIN-DOWEL
92049	92049-016	8	OIL SEAL,RV37129.5
92066	92066-1106	4	PLUG,CYLNDR HD COVER
220	220C0616	8	SCREW-PAN-CROS,6X12,B
411	411B1000	8	WASHER PLAIN 10MM



Ref #	Part Number	Qty	Description
11004	11004-1105	2	GASKET-HEAD,CYLINDER
11008	11008-1045	1	HEAD-COMP-CYLINDER,AP US
11008A	11008-1046	1	HEAD-COMP-CYLINDER (Canada) CN
13034	13034-030	16	BUSHING,CAMSHAFT
16065	16065-1135	4	HOLDER-CARBURETOR
49002	12013-009	4	GUIDE,INLET VALVE
49002A	49002-1002	4	GUIDE,EXHAUST VALVE
92001	92002-1881	16	BOLT,6X43
92004	92004-1069	8	STUD,8X30
92015	92015-1181	12	NUT,FLANGED CAP,10MM
92022	92022-1005	4	WASHER,10.5X22X1.6
92033	92036-023	8	CIRCLIP-VALVE
92037	92037-1304	4	CLAMP,ID=53,BLACK
92043	92042-007	8	PIN-DOWEL
92049	92049-016	8	OIL SEAL,RV37129.5
92066	92066-1104	4	PLUG,CYLINDER HEAD CO
120	120S0616	8	BOLT-SOCKET,6X16,BLAC
130	130S0645	2	BOLT-FLANGED,6X45,BLA
411	411B1000	8	WASHER PLAIN 10MM

E1112-0030

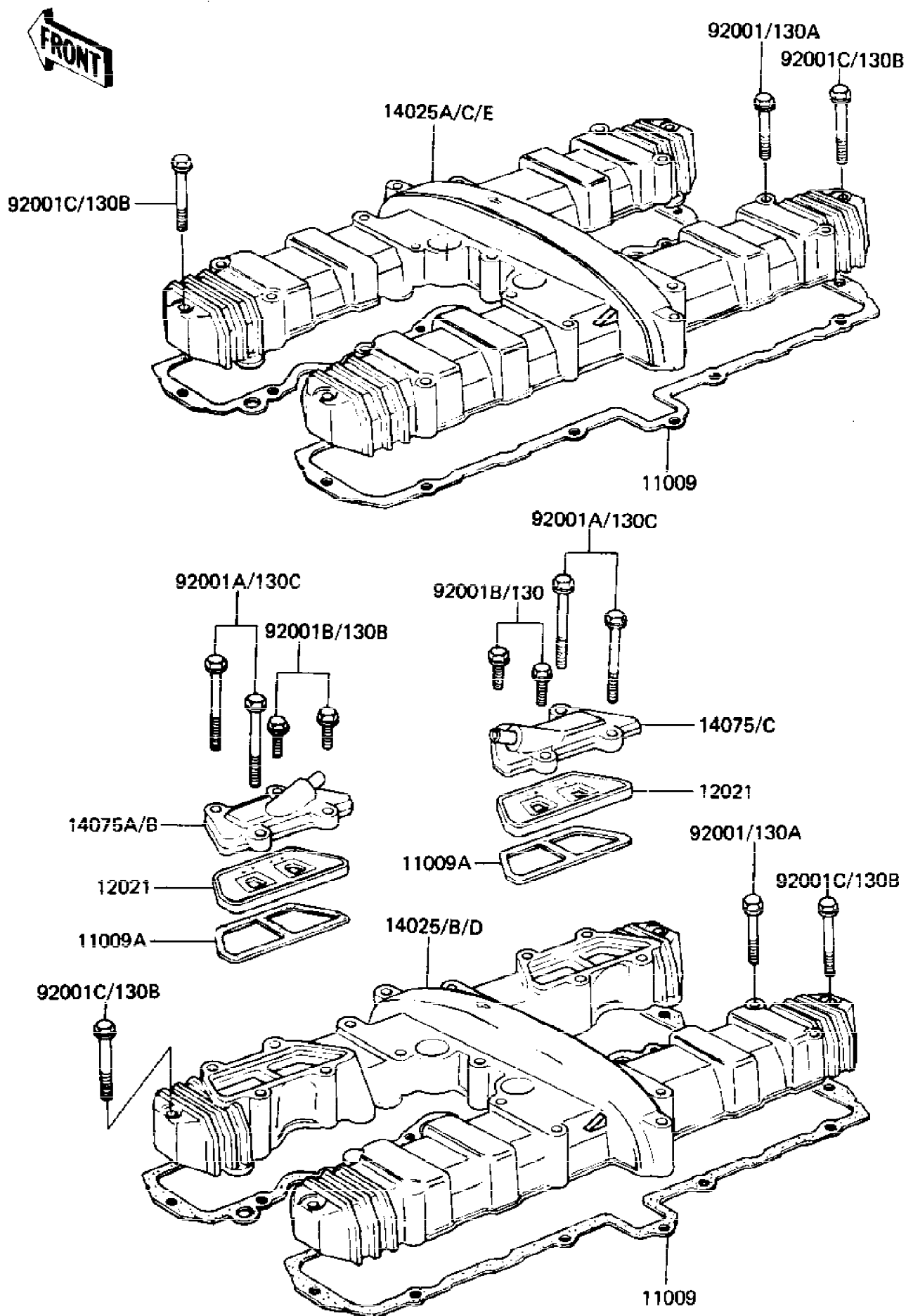

Ref #	Part Number	Qty	Description
11009	11009-1205	1	GASKET,CYLINDER HEAD
11009A	11060-1066	2	GASKET,REED VALVE US
12021	12021-1008	2	VALVE-ASSY-REED US
14025	14025-1463	1	COVER,CYLINDER HEAD,B US
14025A	14025-1248	1	14025-1464 (Canada) CN
14025B	14025-1423	1	COVER,CYLINDER HEAD,B US
14025C	14025-1424	1	14025-1637 (Canada) CN
14025D	14025-1463	1	COVER,CYLINDER HEAD,B US
14025E	14025-1464	1	COVER,CYLINDER HEAD,B CN
14075	14075-5012	1	CAP-ASSY,REED VALVE,R US
14075A	14075-5013	1	CAP-ASSY,REED VALVE,L US
14075B	14075-5022	1	CAP-ASSY,REED VALVE,L US
14075C	14075-5023	1	CAP-ASSY,REED VALVE,R US
92001	92001-1350	16	BOLT,FLANGED,6X45 US
92001	92001-1350	20	BOLT,FLANGED,6X45 US
92001A	92001-1351	4	BOLT,FLANGED,6X70 US
92001B	92001-1352	4	BOLT,FLANGED,6X22 US
92001C	92001-1353	4	BOLT,FLANGED,6X52
130	130J0622	4	BOLT-FLANGED,6X22,BLA US
130A	92002-1069	16	BOLT,6X45 US
130A	92002-1069	20	BOLT,6X45 US
130B	130J0652	4	BOLT-FLANGED,6X52,BLA
130C	130J0670	4	BOLT-FLANGED,6X70,BLA US

E1120-0006

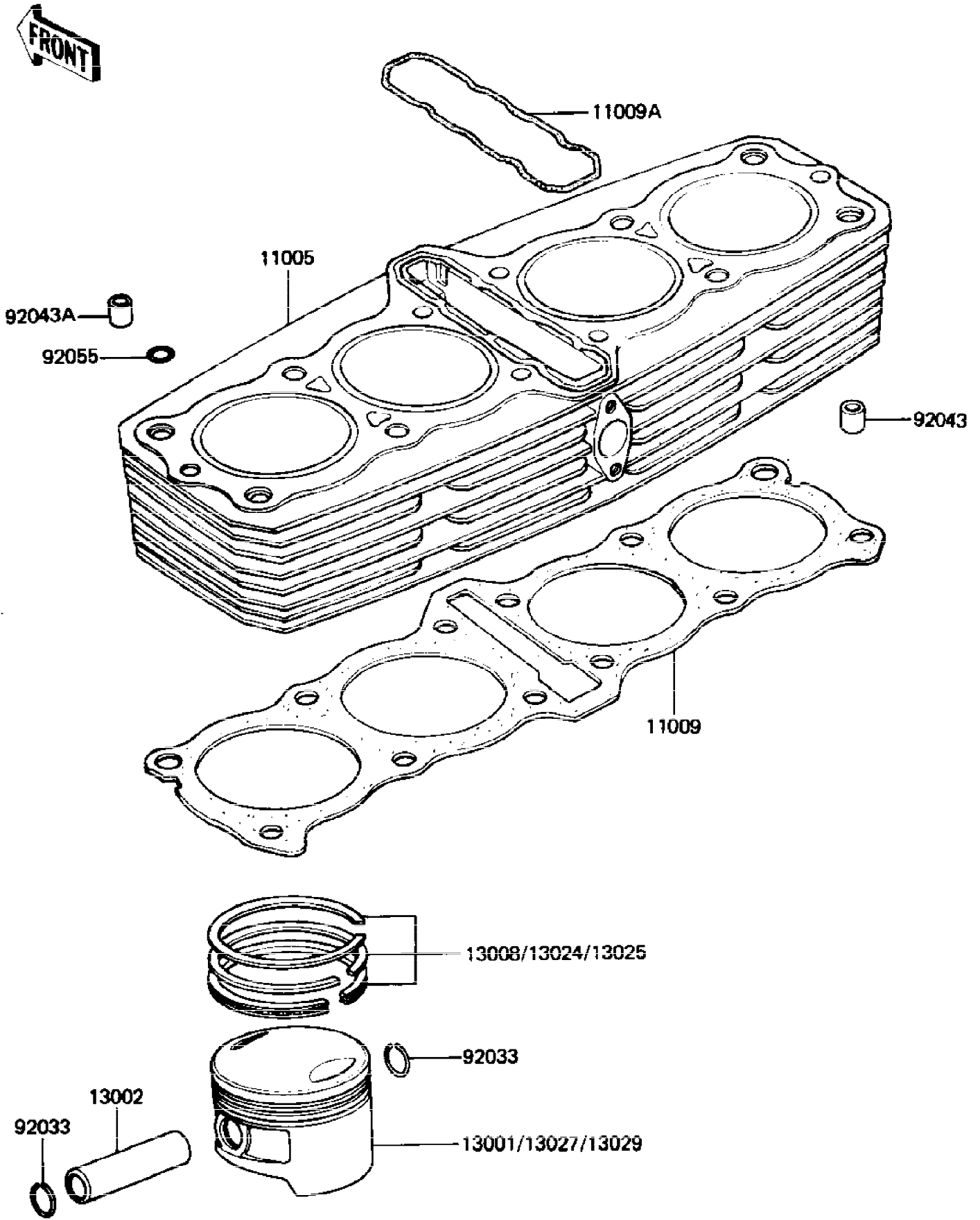

Ref #	Part Number	Qty	Description
11005	11005-1325	1	CYLINDER-ENGINE,BLACK
11009	11060-1067	1	GASKET,CYLINDER BASE
11009A	11009-1208	1	GASKET,CYLINDER
13001	13001-1118	4	PISTON-ENGINE,STD
13002	13002-1013	4	PIN-PISTON
13008	13008-5037	4	RING-SET-PISTON,STD
13024	13024-5023	4	RING-SET PISTON LL
13025	13025-5019	4	RING-SET PISTON L,O/S
13027	13027-1055	4	PISTON-ENGINE LL,O/S
13029	13029-1057	4	PISTON-ENGINE L,O/S
92033	92033-1054	8	RING-SNAP
92043	92043-1266	2	PIN,11X14X12.3
92043A	92043-1037	2	PIN,DOWEL,10X8.2X14
92055	92055-1148	4	RING-0,0D=18.5MM



E1431-0067

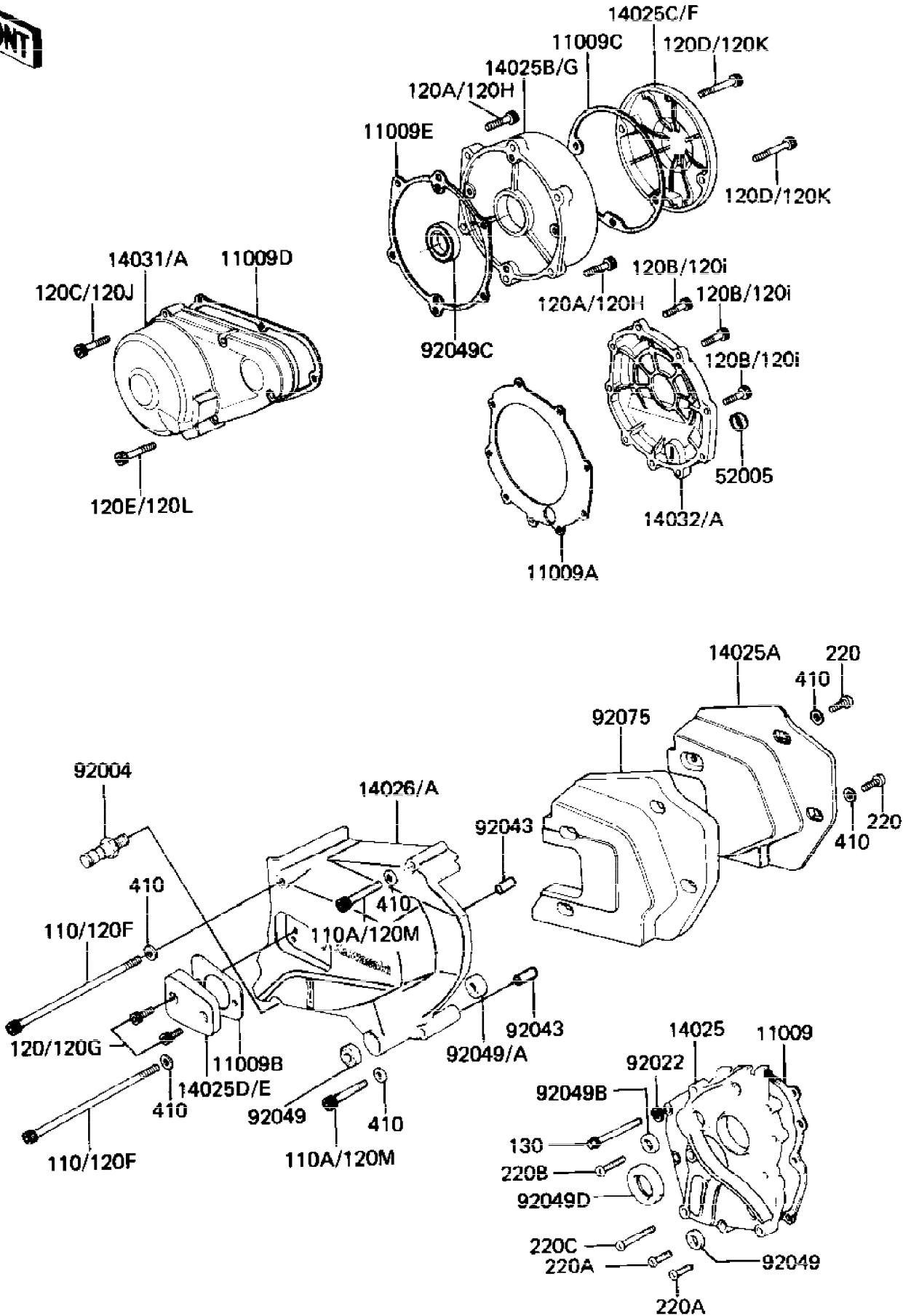

Ref #	Part Number	Qty	Description
111009	11060-1069	1	GASKET,TRANSMISSION C
111009A	11060-1070	1	GASKET,CLUTCH COVER
111009B	11060-1073	1	GASKET,CLUTCH ADJUSTI
111009C	11060-1072	1	GASKET,PULSING COIL C
111009D	11060-1075	1	GASKET,GENERATOR COVE
111009E	11060-1071	1	GASKET,RH ENGINE COVE
14025	14025-1240	1	COVER,TRANSMISSION
14025A	14025-1252	1	COVER,SOUND ARRESTER
14025B	14025-1279	1	COVER,ENGINE,RH,BLACK
14025C	14025-1280	1	COVER,PULSING COIL,B
14025D	14025-1367	1	COVER,CLUTCH ADJUSTIN
14025E	14025-1409	1	COVER,CLUTCH RELEASES
14025F	14025-1610	1	COVER
14025G	14025-1426	1	COVER,ENGINE,RH,BLACK
14026	14026-1048	1	COVER-CHAIN,BLACK
14026A	14026-1066	1	COVER-CHAIN,BLACK
14031	14031-1062	1	COVER-GENERATOR,BLACK
14031A	14031-1082	1	COVER-GENERATOR,BLACK
14032	14032-1058	1	COVER-CLUTCH
14032A	14032-1075	1	COVER-CLUTCH,BLACK
52005	52005-1009	1	GAUGE,OIL LEVEL
92004	92004-1034	1	STUD,CHANGE PEDAL PIV
92022	92022-077	1	WASHER OIL PUMP BANJO
92043	92042-007	2	PIN-DOWEL
92049	92049-004	3	OIL SEAL SB12205
92049	92049-004	1	OIL SEAL SB12205
92049A	92049-1003	1	OIL SEAL,CLUTCH RELES
92049B	92049-1017	1	OIL SEAL,SD-8187
92049C	92049-1033	1	OIL SEAL,SC32487
92049D	92049-1070	1	SEAL-OIL
92075	92075-1269	1	DAMPER,SOUND
110	112G06125	2	BOLT-UPSET,6X125
110A	110G0670	2	BOLT,6X70
120	120P0614	2	BOLT,6X14
120A	120P0622	6	BOLT,SOCKET,6X22
120B	120P0625	9	BOLT,6X25
120C	120P0630	6	BOLT,SOCKET,6X30
120D	120P0635	2	BOLT,SOCKET,6X35
120E	120P0640	2	BOLT,SOCKET,6X40
120F	120S06125	2	BOLT-SOCKET,6X125,BLA
120G	120S0614	2	BOLT-SOCKET,6X14,BLAC
120H	92002-1326	6	BOLT,SOCKET,6X22
120I	120S0625	9	BOLT,SOCKET,6X25,BLAC
120J	120S0630	6	BOLT,SOCKET,6X30,BLAC
120K	120S0635	2	BOLT-SOCKET,6X35,BLAC
120L	120S0640	2	BOLT-SOCKET,6X40
120M	120S0670	2	BOLT-SOCKET,6X70,BLAC
130	130G0655	1	BOLT,FLANGED,6X55
220	220B0612	4	SCREW PAN HEAD 6X12
220A	220B0620	6	SCREW PAN HEAD 6X20
220B	220B0628	1	SCREW PAN HEAD 6X28
220B	220B0640	2	SCREW PAN HEAD 6X40
410	410B0600	8	WASHER PLAIN 6MM
410	410B0600	4	WASHER PLAIN 6MM

F2871-0005

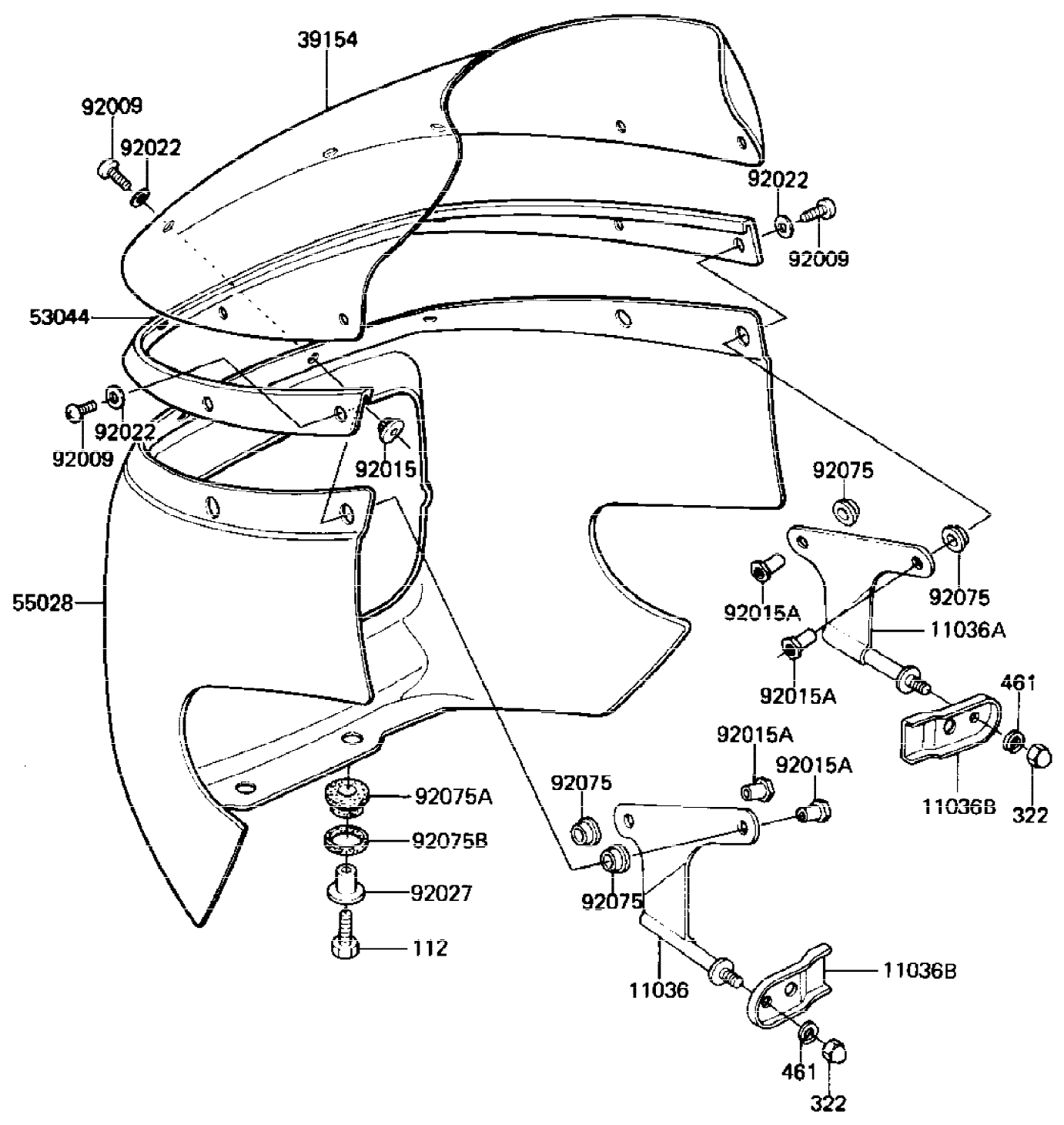

Ref #	Part Number	Qty	Description
11036	11036-1349	1	BRACKET-A,COWLING,LH,
11036A	11036-1350	1	BRACKET-A,COWLING,RH,
11036B	11036-1439	2	BRACKET-A,COWLING
39154	39154-1008	1	WINDSHIELD
53044	53044-1036	1	TRIM,COWLING
55028	55028-1012-B1	1	COWLING,F.RED
92009	220C0512	7	SCREW-PAN-CROS,5X12,B
92015	92015-1025	3	NUT,5M/M
92015A	92015-1150	4	NUT,5MM
92022	92022-1038	7	WASHER,PLAIN
92027	92027-1450	2	COLLAR,L=13.1,BLACK
92075	92075-1138	4	DAMPER,PILOT LAMP
92075A	92075-174	2	RUBBER,FENDER COVER
92075B	92075-175	2	DAMPER RUBBER
112	112C0625	2	BOLT-UPSET,6X25,BLACK
322	322C0600	2	NUT-CAP,6MM,BLACK
461	461K0600	2	WASHER-SPRING,6MM,BLA

F2170-0038

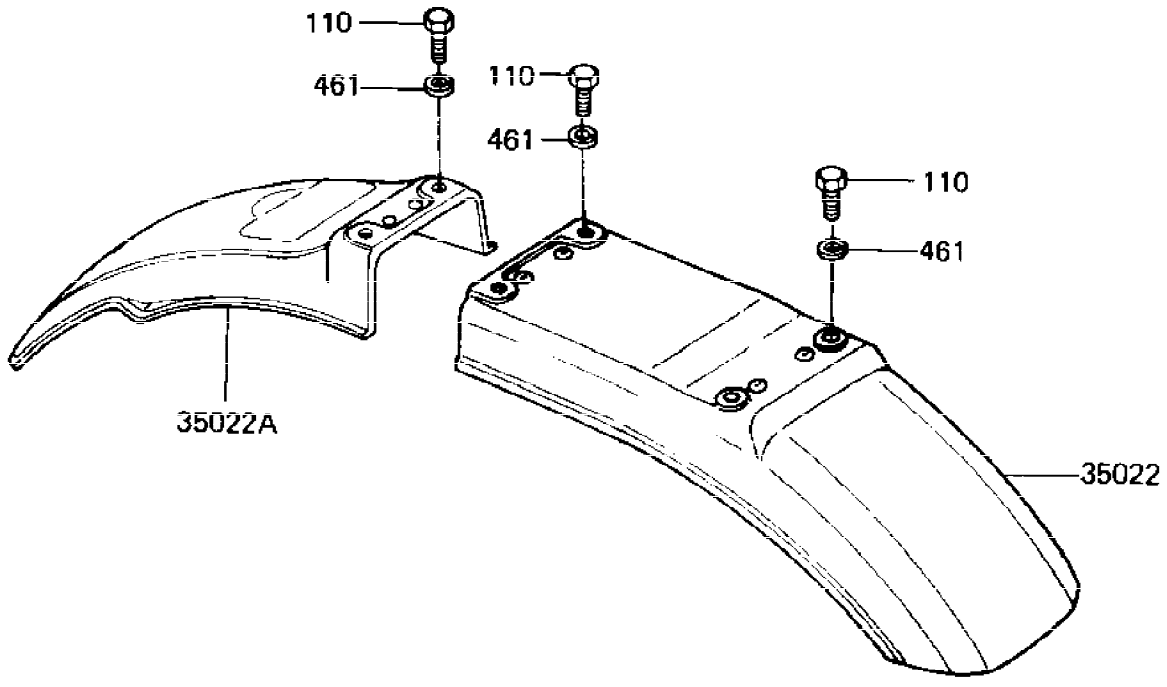
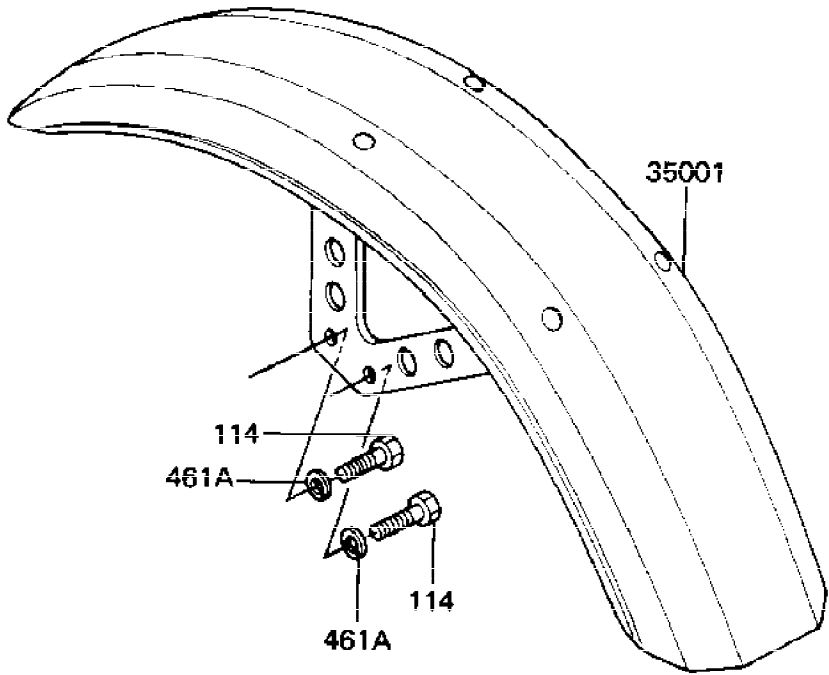

Ref #	Part Number	Qty	Description
35001	35001-1030-B1	1	FENDER-FR,RED
35022	35022-1069-6Z	1	FENDER-RR,BLACK
35022A	35022-1071	1	FENDER-RR
110	112G0620	6	BOLT-UPSET,6X20
114	115G0816	4	BOLT-SMALL-UPSET,8X16
461	461F0600	6	WASHER SPRING 6MM
461A	461F0800	4	WASHER SPRING 8MM

F2160-0059

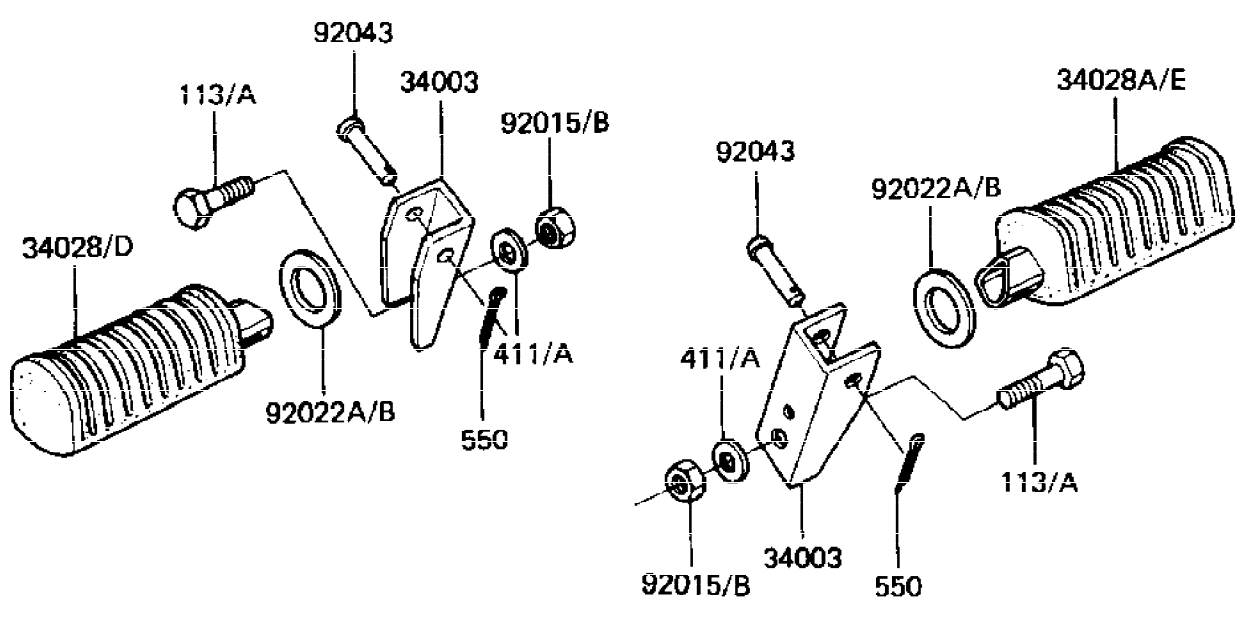
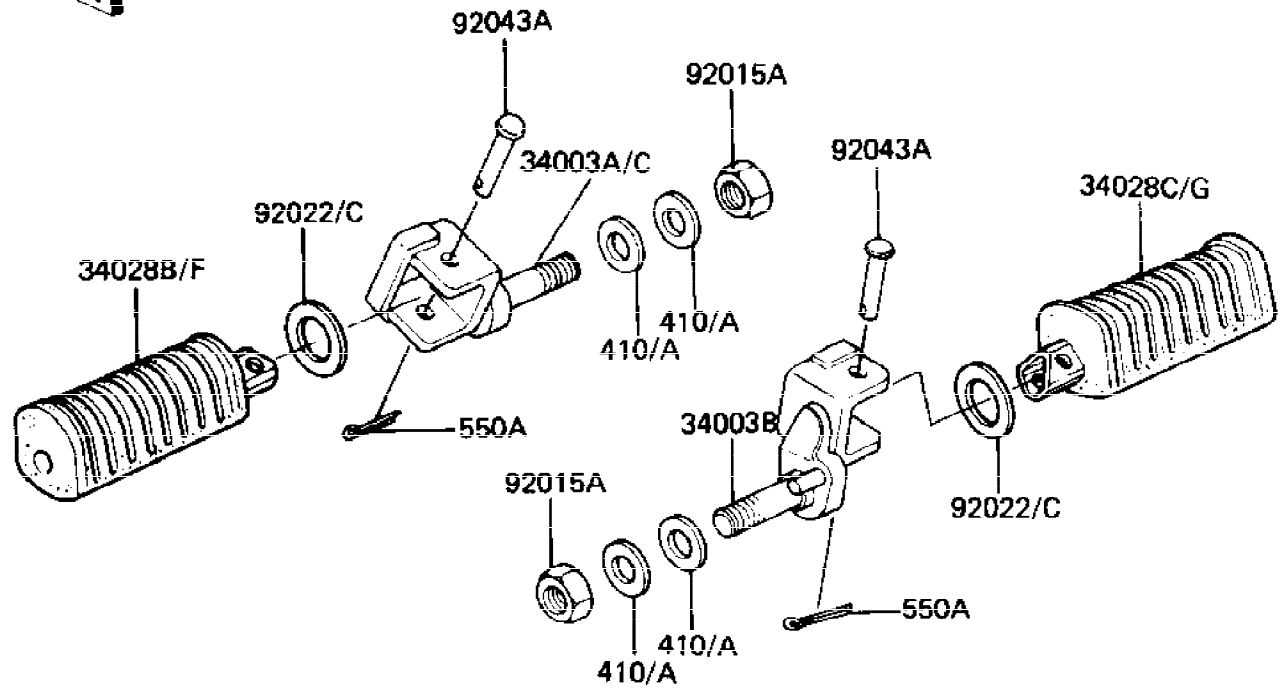

Ref #	Part Number	Qty	Description
34003	34003-1025	2	HOLDER,REAR FOOTREST
34003A	34003-1114	1	HOLDER-STEP,FR,LH (SUBSTITUTES 34003-1114 )
34003B	34003-1086	1	HOLDER-STEP,FR,RH
34003C	34003-1114	1	HOLDER-STEP,FR,LH
34028	34028-1024	1	STEP,RR FOOTREST,L.H
34028A	34028-1025	1	STEP,RR FOOTREST,R.H
34028B	34027-1106	1	STEP-ASSY,FR,LH
34028C	34027-1107	1	STEP-ASSY,FR,RH
34028D	34028-1041	1	STEP,RR,LH,BLACK
34028E	34028-1042	1	STEP,RR,RH,BLACK
34028F	34027-1108	1	STEP-ASSY,FR,LH,BLACK
34028G	34027-1109	1	STEP-ASSY,FR,RH,BLACK
92015	92015-1188	2	NUT,LOCK,10MM,BLACK
92015A	92019-009	2	NUT-LOCK,12MM
92015B	92019-021	2	NUT,LOCK,10MM
92022	92022-1319	2	WASHER,25X36X2.3,BLAC
92022A	92022-1320	2	WASHER,22.5X30X2.6,BL
92022B	92022-181	2	WASHER-PLAIN
92022C	92022-250	2	WASHER,PLAIN
92043	92043-1464	2	PIN
92043A	92043-115	2	PIN,FOOTREST BAR FIT
113	92001-1253	2	BOLT,HEX HEAD 10X40
113A	113J1040	2	BOLT-SMALL-FINE,10X40
410	410B1200	4	WASHER PLAIN 12MM
410A	410F1200	4	WASHER-PLANE-SMALL
411	411B1000	2	WASHER PLAIN 10MM
411A	411F1000	2	WASHER
550	550D2012	2	PIN,COTTER,2.0X12
550A	550D2515	2	PIN,COTTER,2.5X15



F2120-0113

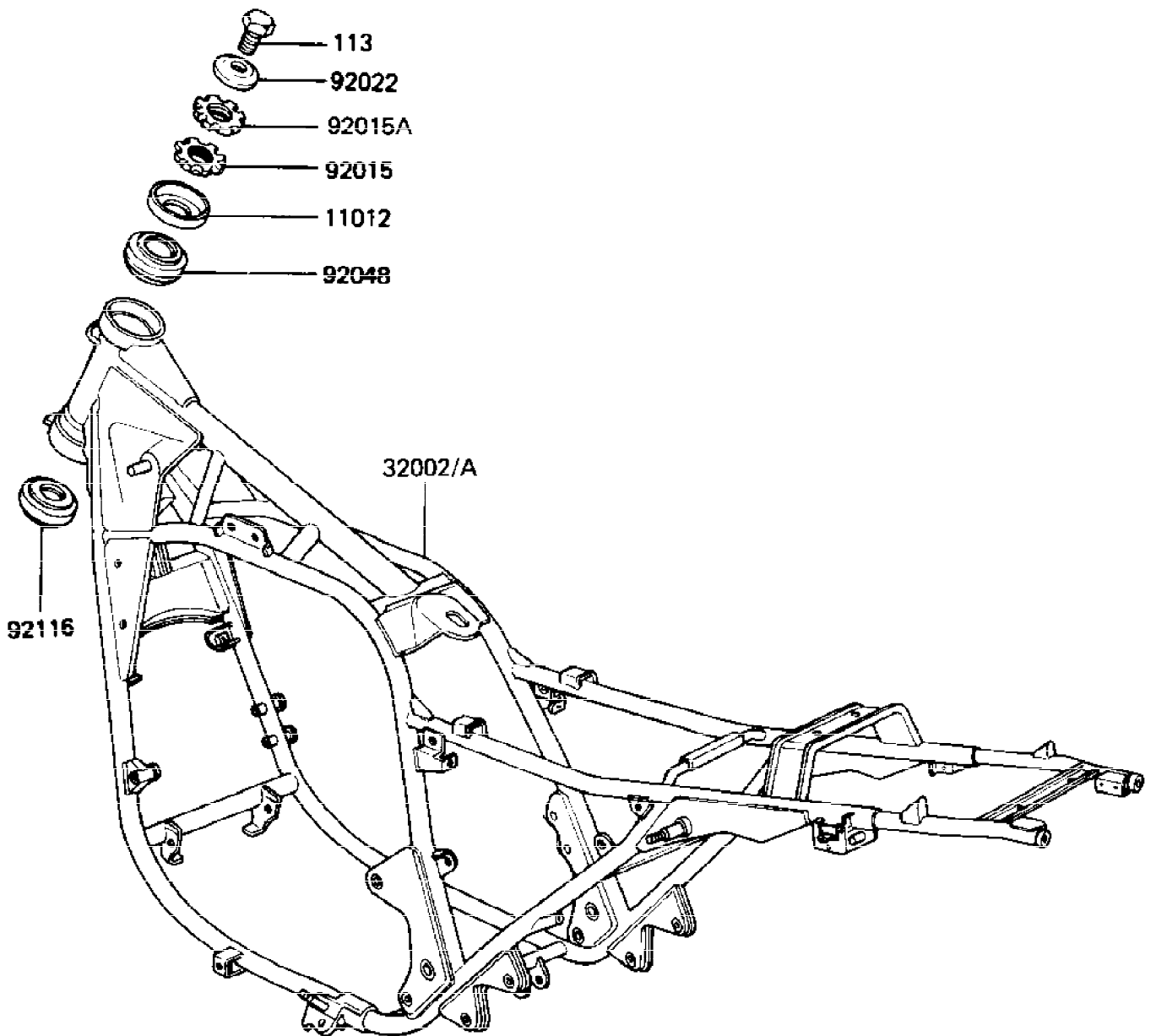

Ref #	Part Number	Qty	Description
11012	46098-017	1	CAP,STEERING STEM
32002	32002-1265	1	FRAME-COMP
32002A	32002-1445	1	FRAME-COMP,US
92015	92015-1128	1	NUT
92015A	92015-1129	1	NUT
92022	92022-1229	1	WASHER
92048	92047-017	1	BEARING,STEERING STEM
92116	92116-1009	1	BRG,ROLLER,HR320/28XJ
113	113G1425	1	BOLT-SMALL-FINE

F2131-0097

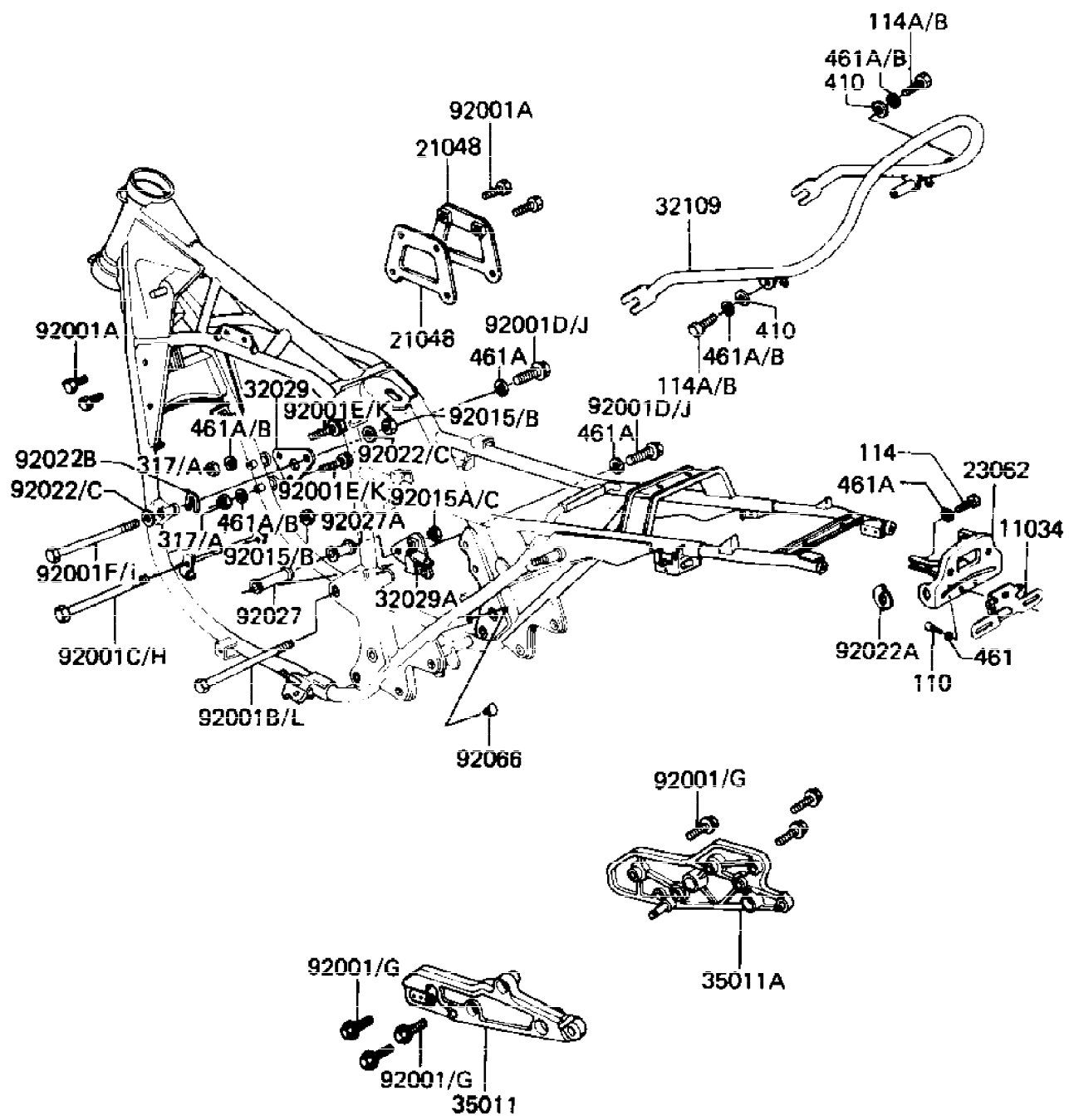
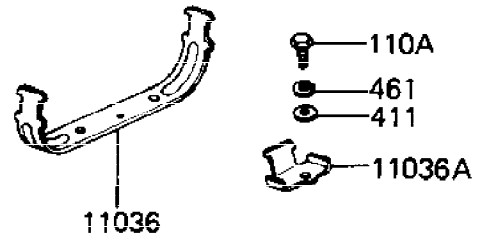

Ref #	Part Number	Qty	Description
11034	11034-1922	1	BRACKET
11036	11036-1065	1	BRACKET-A,CNTRL UNIT
11036A	11036-1066	1	BRACKET-A,CNTRL UNIT
21048	21048-1001	2	PLATE,IGNITION COIL
23062	23062-1032	1	BRACKET-COMP,TL LAMP
32029	32029-1142	1	BRACKET-ENGINE
32029A	32029-1153	1	BRACKET-ENGINE,RR,RH
32109	32109-1029	1	GRIP-FRAME
35011	35011-1207	1	STAY,MUFFLER,LH
35011A	35011-1208	1	STAY,MUFFLER,RH
92001	92001-1095	6	BOLT,8X28
92001A	92001-137	4	BOLT,HEX HEAD,6MM
92001B	92001-1655	1	BOLT,FLANGED,12X285
92001C	92001-1585	1	BOLT
92001D	92001-1579	2	BOLT,FLANGED,8X45
92001E	92001-1582	2	BOLT-FLANGE
92001F	92001-1624	1	BOLT,FLANGED,10X320,B
92001G	92001-1508	6	BOLT,FLANGED,8X28,BLA
92001H	92001-1620	1	BOLT,FLANGED,10X155,B
92001I	92001-1624	1	BOLT,FLANGED,10X320,B
92001J	92001-1613	2	BOLT,FLANGED,8X45
92001K	92001-1616	2	BOLT,FLANGED,8X65,BLA
92001L	92001-1655	1	BOLT,FLANGED,12X285
92015	92015-1189	2	NUT,LOCK,10MM,BLACK
92015A	92015-1190	1	NUT,LOCK,12MM,BLACK
92015B	92015-1429	2	NUT,10MM
92015C	92019-009	1	NUT-LOCK,12MM
92022	92022-1022	2	WASHER,PLAIN
92022A	92022-1230	2	WASHER,SIGNAL LAMP BR
92022B	92022-1259	1	WASHER,U FORMED
92022C	92022-1022	2	WASHER,PLAIN
92027	92027-1310	1	COLLAR,13X25X54
92027A	92027-1311	1	COLLAR,13X25X29.5
92066	92066-1034	1	PLUG,FRAME END
110	112G0612	2	BOLT-UPSET,6X12
110A	112B0614	1	BOLT-UPSET 6X14
114	115G0816	4	BOLT-SMALL-UPSET,8X16
114A	114B0870	2	BOLT HEX HEAD 8X70
114B	115C0870	2	BOLT-SMALL,8X70,BLACK
317	317B0800	2	NUT,8M/M
317A	317C0800	2	NUT-HEX-SMALL,8MM,BLA
410	410B0800	2	WASHER PLAIN 8MM
411	411B0600	1	WASHER PLAIN 6MM
461	461F0600	3	WASHER SPRING 6MM
461A	461F0800	10	WASHER SPRING 8MM
461A	461F0800	6	WASHER SPRING 8MM
461B	461K0800	4	WASHER-SPRING,8MM,BLA

F2292-0028

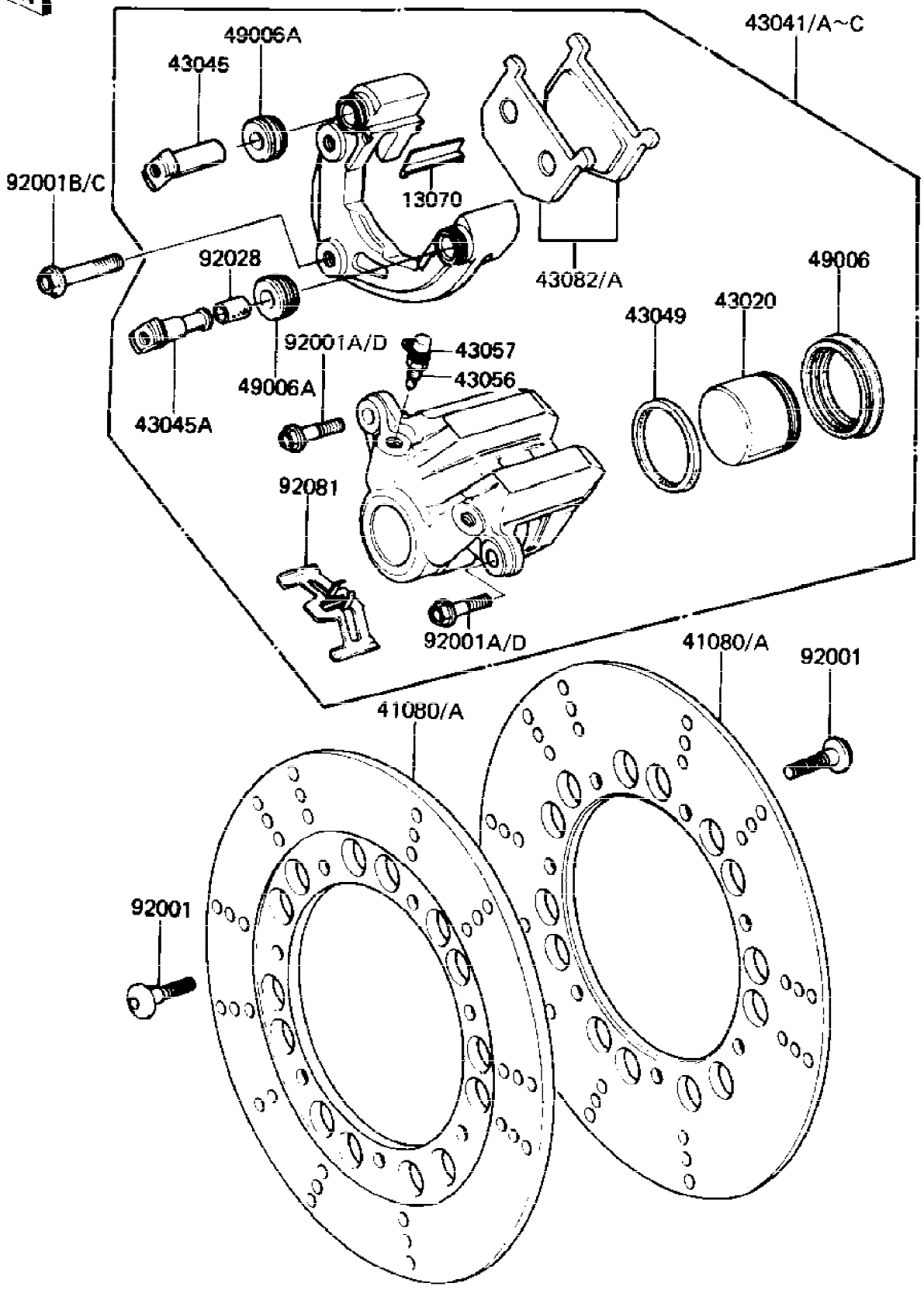

Ref #	Part Number	Qty	Description
13070	13070-1026	4	GUIDE,PAD
41080	41080-1127	2	DISC,FR,SILVER
41080A	41080-1038	2	DISK,FR
43020	43020-1096	2	PISTON-COMP-BRAKE
43041	43041-1045	1	CALIPER-ASSY,FR,LH
43041A	43041-1046	1	CALIPER-ASSY,FR,RH
43041B	43041-1053	1	CALIPER-ASSY,FR,LH
43041C	43041-1054	1	CALIPER-ASSY,FR,RH
43045	43045-1007	2	SHAFT,CALIPER
43045A	43045-1008	2	SHAFT,CALIPER
43049	43049-002	2	RING,PISTON SEAL
43056	43056-003	2	BREEDER
43057	43057-003	2	CAP,BREEDER
43082	43082-1021	2	PAD-ASSY,FR
43082A	43082-1026	2	PAD-ASSY-BRAKE
49006	49006-1043	2	DUST SEAL,PISTON
49006A	49006-1044	4	DUST SEAL
92001	92001-1951	14	BOLT,SOCKET,8X30
92001A	92001-1510	4	BOLT,FLANGED,8X25,BLA
92001B	92001-1355	4	BOLT,FLANGED,10X41
92001C	92001-1507	4	BOLT,FLANGED,10X41,BL
92001D	92001-1510	4	BOLT,FLANGED,8X25,BLA
92028	92028-1090	2	BUSHING,SHAFT CALIPER
92081	92081-1229	2	SPRING,PAD

F2340-0033

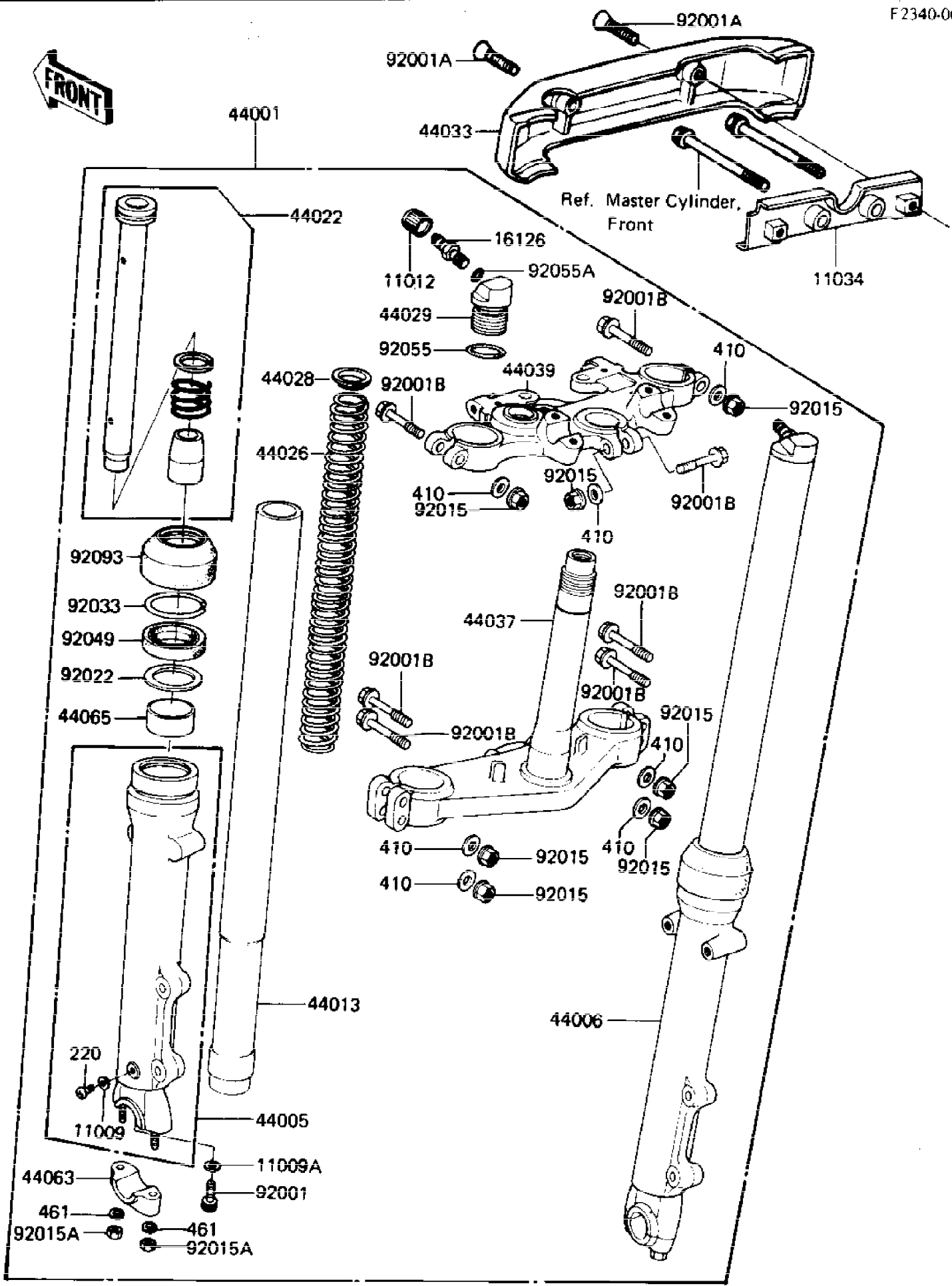

Ref #	Part Number	Qty	Description
11009	44045-002	2	GASKET FORK DRAIN PLG
11009A	44045-057	2	GASKET,FORK CYLINDER
11012	11012-1241	2	CAP,AIR VALVE
11034	11034-1842	1	BRACKET,FORK COVER
16126	16126-1052	2	VALVE AIR
44001	44001-1283	1	FORK-FRONT
44005	44005-1072	1	TUBE,LH,FORK OUTER
44006	44006-1072	1	TUBE,RH,FORK OUTER
44013	44013-1066	2	PIPE-FORK INNER
44022	44022-1062	2	CYLINDER-FORK
44026	44026-1115	2	SPRING-FRONT FORK
44028	44028-1004	2	GUIDE,FORK SPRING
44029	44029-1021	2	SEAT-FORK SPRING
44033	44033-1053	1	COVER,FORK
44037	44037-1072	1	HOLDER-FORK UNDER
44039	44039-1045	1	HOLDER-FORK UPPER
44063	44063-1006	2	HOLDER-FRONT AXLE
44065	44065-1091	2	BUSHING-FRONT FORK,OU
92001	44041-040	2	BOLT-FORK CYLINDER
92001A	222C0518	2	SCREW-CSK-RD-CROS
92001B	92001-1358	7	BOLT,FLANGED,8X57
92015	92015-1022	7	NUT-8MM
92015A	92015-1124	4	NUT,LOCK,8MM
92022	92022-1262	2	WASHER,FORK OUT PIPE
92033	92033-1047	2	SNAP RING,FORK OUTER
92049	92049-1295	2	SEAL-OIL,FORK OUTER T
92055	92055-1051	2	"O" RING,FORK TOP
92055A	92055-1094	2	"O" RING,AIR VALVE
92093	92093-1051	2	SEAL
220	220B0408	2	SCREW PAN HEAD 4X8
410	410B0800	7	WASHER PLAIN 8MM
461	461F0800	4	WASHER SPRING 8MM



F2340-0102

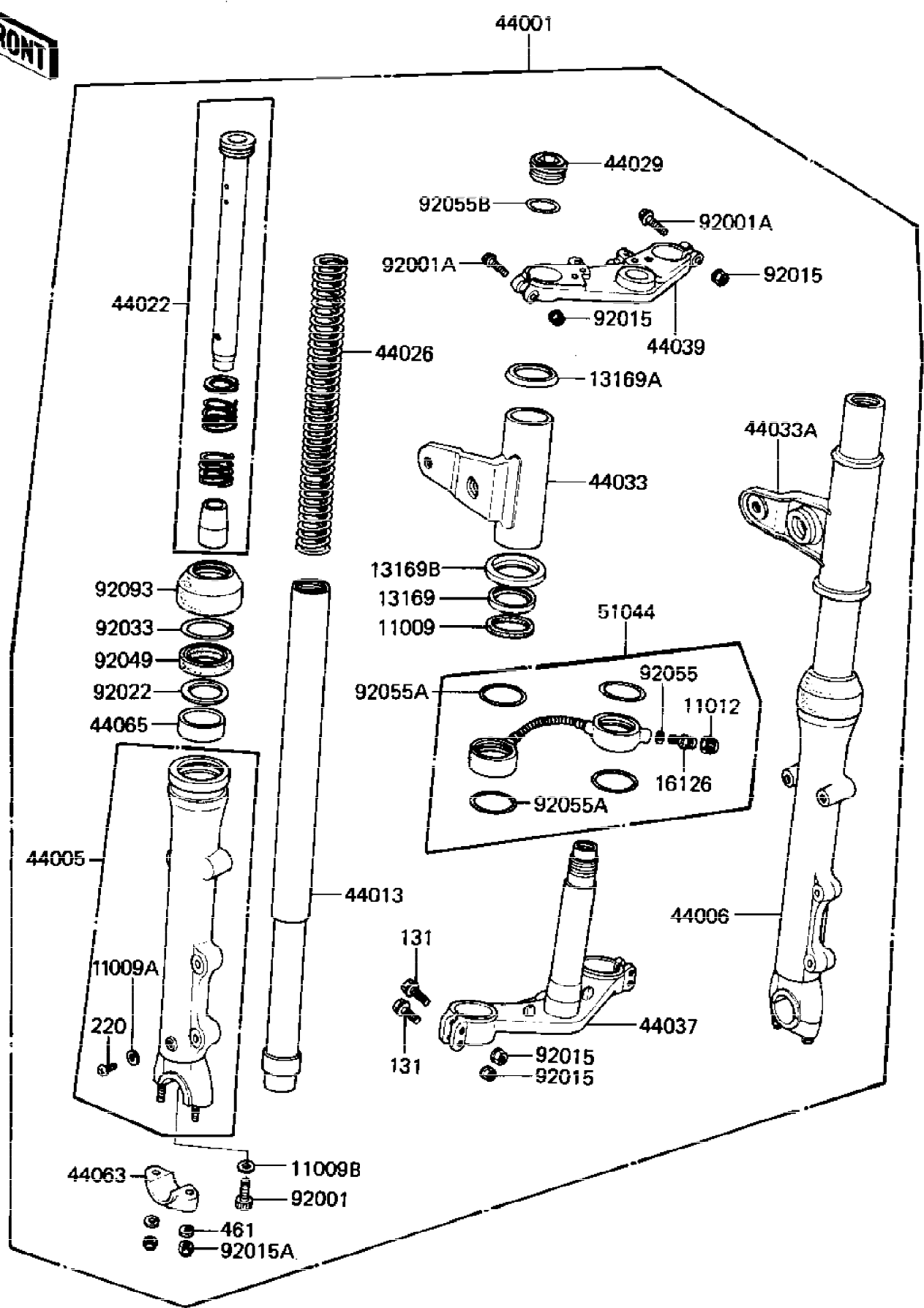

Ref #	Part Number	Qty	Description
11009	11009-1015	2	GASKET,FORK COVER
11009A	44045-002	2	GASKET FORK DRAIN PLG
11009B	44045-057	2	GASKET,FORK CYLINDER
11012	11012-1241	2	CAP,AIR VALVE
13169	13169-1020	2	WASHER,FRK COVER GIDE
13169A	13169-1498	2	PLATE,FORK COVER,UPP
13169B	13169-1499	2	PLATE,FORK COVER,LWR
16126	16126-1052	1	VALVE AIR
44001	44001-1338	1	FORK-FRONT
44005	44005-1094	1	TUBE,LH,FORK OUTER
44006	44006-1094	1	TUBE,RH,FORK OUTER
44013	44013-1094	2	PIPE-FORK INNER,INNER
44022	44022-1063	2	CYLINDER-FORK
44026	44026-1147	2	SPRING-FRONT FORK
44029	44029-1036	2	SEAT-FORK SPRING
44033	44033-1085	1	COVER-FORK-LH,F.BLACK
44033A	44033-1086	1	COVER-FORK,RH,F.BLACK
44037	44037-1072	1	HOLDER-FORK UNDER
44039	44039-1052	1	HOLDER-FORK UPPER
44063	44063-1006	2	HOLDER-FRONT AXLE
44065	44065-1091	2	BUSHING-FRONT FORK,OU
51044	51044-1021	1	TUBE-ASSY,AIR,FORK
92001	44041-040	2	BOLT-FORK CYLINDER
92001A	92001-1572	2	BOLT,FLANGED,8X57,BLA
92015	92015-1408	6	NUT,FLANGED,8MM
92015A	92015-1205	4	NUT,U,8MM,BLACK
92022	92022-1262	2	WASHER,FORK OUT PIPE
92033	92033-1047	2	SNAP RING,FORK OUTER
92049	92049-1295	2	SEAL-OIL,FORK OUTER T
92055	92055-1094	1	"O" RING,AIR VALVE
92055A	92055-1369	4	RING-O,ROD
92055B	92055-1135	2	RING-O,FORK SPRING SE
92093	92093-1051	2	SEAL
131	131J0855	4	BOLT-FLANGED,8X55,BLA
220	220B0408	2	SCREW PAN HEAD 4X8
461	461K0800	4	WASHER-SPRING,8MM,BLA



Ref #	Part Number	Qty	Description
14008	14008-1007	1	LINER,PISTON
27010	27010-1028	1	SWITCH,BRAKE
43015	43015-1081	1	CYLINDER-ASSY-MASTER
43020	43020-1023	1	PISTON-COMP-BRAKE
43022	43022-1001	1	STOPER,PISTON
43026	43026-1006	1	CAP,OIL CUP
43028	43028-1008	1	DIAPHRAGM
43034	43034-1001	1	HOLDER,MASTER CYLINDR
43059	43059-1198	2	HOSE-BRAKE,FR,L=550
43059A	43059-1183	1	HOSE-BRAKE,FR,L=370
43061	43061-1004	1	JOINT BRAKE
46092	46092-1023	1	LEVER-GRIP,BRAKE,FR
49006	49006-1041	1	BOOT,DUST
49016	49016-1010	1	DUST COVER
92001	43033-003	2	BOLT,HEX HEAD,6X25
92001A	92002-1888	4	BOLT,OIL,L=23
92001B	92001-1055	2	SCREW,COUNTERSUNK HED
92001C	92001-1056	1	BOLT,CLUTCH LEV FITT
92001D	92002-1909	1	BOLT
92015	312B0600	1	NUT 6MM
92022	43067-001	11	WASHER-OIL BOLT
92037	43064-006	2	DAMPER RUBBER,CYL HSE
92037A	92037-1217	1	CLAMP,BRAKE HOSE,RH
92037B	92037-1231	1	CLAMP,BRAKE HOSE,LH
110	112G0612	2	BOLT-UPSET,6X12
130	130G0665	2	BOLT,FLANGED,6X65
461	461F0600	2	WASHER SPRING 6MM

F2291-0058

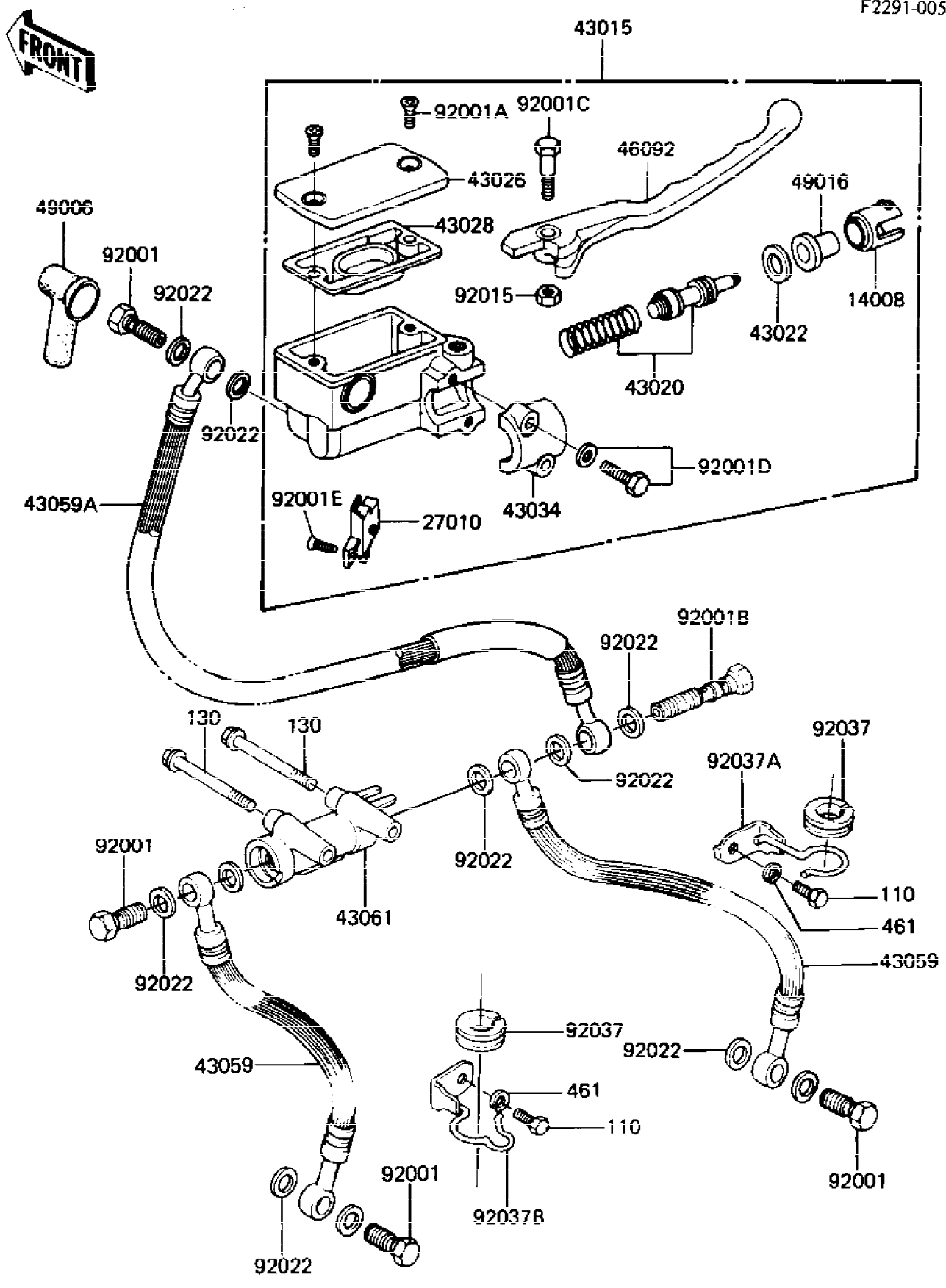

Ref #	Part Number	Qty	Description
14008	14008-1035	1	LINER,PISTON
27010	27010-1056	1	SWITCH,BRAKE
43015	43015-1085	1	CYLINDER-ASSY-MASTER
43020	43020-1079	1	PISTON-COMP-BRAKE
43022	43022-1009	1	STOPPER-BRAKE,PISTON
43026	43026-1017	1	CAP-BRAKE,FRONT
43028	43028-1029	1	DIAPHRAGM,MASTER CYL1
43034	43034-1013	1	HOLDER-BRAKE,MASTER C
43059	43059-1198	2	HOSE-BRAKE,FR,L=550
43059A	43059-1133	1	HOSE-BRAKE,FR,L=360
43061	43061-1004	1	JOINT BRAKE
46092	46092-1026	1	LEVER-GRIP,MASTER CYL
49006	49006-1067	1	BOOT,DUST
49016	49016-1041	1	COVER-SEAL,BRK PISTON
92001	92002-1888	4	BOLT,OIL,L=23
92001A	92001-1055	2	SCREW,COUNTERSUNK HED
92001B	92002-1909	1	BOLT
92001C	92001-1512	1	BOLT,6X37.3,BLACK
92001D	92001-1513	2	BOLT,W/WASHER,6X25,BL
92001E	92001-1532	1	SCREW-COUNTERSUNK
92015	92015-1191	1	NUT,LOCK,6MM,BLACK
92022	43067-001	11	WASHER-OIL BOLT
92037	43064-006	2	DAMPER RUBBER,CYL HSE
92037A	92037-1217	1	CLAMP,BRAKE HOSE,RH
92037B	92037-1296	1	CLAMP,BRAKE HOSE,LH
110	112C0612	2	BOLT, 6X12, BLACK
130	130G0660	2	BOLT-FLANGED,6X60
461	461K0600	2	WASHER-SPRING,6MM,BLA

F2230-0054

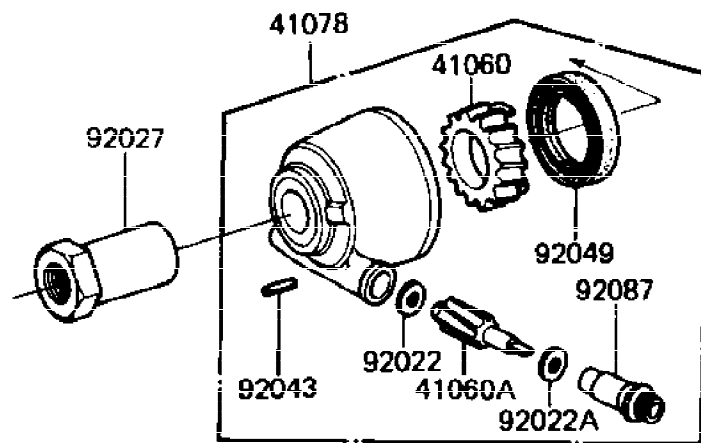
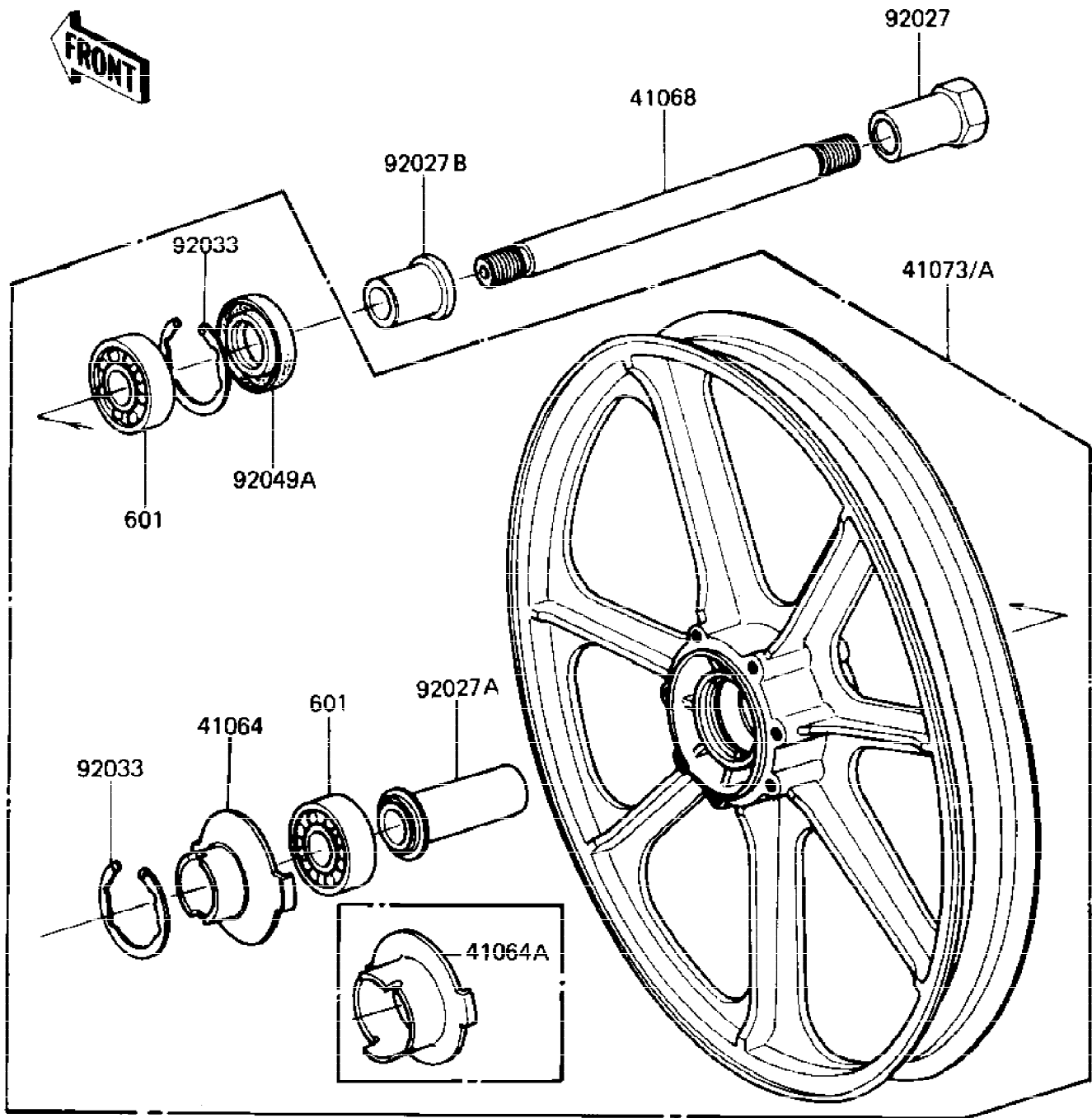

Ref #	Part Number	Qty	Description
41060	41059-026	1	GEAR,SPEEDOMETER
41060A	41060-1016	1	PINION,SPEEDOMETER,9T
41064	41064-1006	1	RECEIVER,SPEEDOMETER
41064A	41064-1008	1	RECEIVER-SPEEDOMETER
41068	41068-1031	1	AXLE,FRONT
41073	41073-1156-21	1	WHEEL-ASSY
41073A	41073-1139-21	1	WHEEL-ASSY,FR,SOLID,B
41078	41078-1024	1	CASE-ASSY-METER GEAR,
92022	41063-001	1	WASHER THRST SPD PINI
92022A	41063-001	1	WASHER THRST SPD PINI
92027	41069-031	2	COLLAR,FRONT AXLE
92027A	92027-1223	1	COLLAR,FR HUB L=55M/M
92027B	92027-1225	1	COLLAR,FR AXLE L=30MM
92033	92033-1041	2	CIRCLIP,42MM
92043	41082-001	1	PIN,SPRING
92049	92049-1057	1	OIL SEAL,BJN30427-C3
92049A	92049-1058	1	OIL SEAL,AG1144AO
92087	92087-1002	1	BUSHING,METER GEAR
601	601B6302Z	2	BEARING BALL #6302Z



E1520-0002

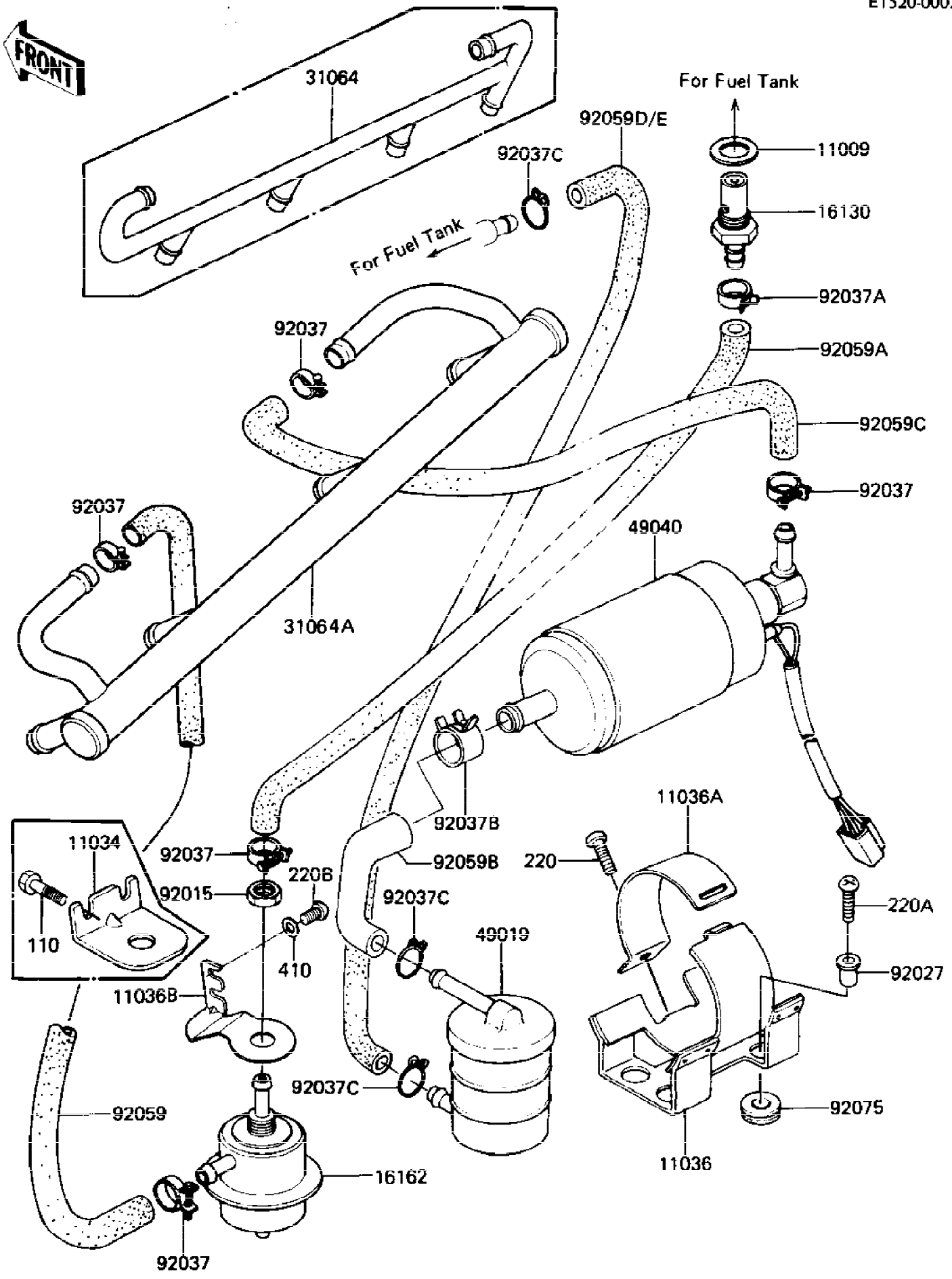

Ref #	Part Number	Qty	Description
11009	11009-1182	1	GASKET,RELIEF VLV FIT
11034	11034-1723	1	BKT,PRESSURE REGULATO
11036	11036-1182	1	BRACKET-A,FUEL PUMP,L
11036A	11036-1183	1	BRACKET-A,FUEL PUMP,U
11036B	11036-1447	1	BRACKET-A,P REGULATOR
16130	16130-1002	1	VALVE ASSY,RELIEF
16162	16162-1002	1	REGULATOR-FUEL
31064	31064-1002	1	PIPE ASSY
31064A	31064-1004	1	PIPE-COMP,FUEL
49019	49019-1001	1	FILTER,FUEL
49040	49040-1003	1	PUMP-FUEL
92015	92015-1101	1	NUT,12M/M
92027	92027-194	4	COLLAR
92037	92037-1178	5	CLAMP
92037A	92037-1181	1	CLAMP
92037B	92037-1365	1	CLAMP,FUEL TUBE,ID-15
92037C	92037-1271	3	CLAMP,FUEL TUBE
92059	92059-1122	1	TUBE,7.5X13.5X285
92059A	92059-1134	1	TUBE
92059B	92059-1165	1	TUBE,FUEL PUMP
92059C	92059-1176	1	TUBE,FUEL PUMP,L=330
92059D	92059-1195	1	TUBE,FUEL PUMP
92059E	92059-1231	1	TUBE,FL,7.5X13.5X500
92075	92075-277	4	DAMPER RUBBER
110	110B0510	2	BOLT HEX HEAD 5X10
220	220B0514	1	SCREW-PAN-CROS
220A	220B0620	4	SCREW PAN HEAD 6X20
220B	220C0508	2	SCREW-PAN-CROS
410	410F0500	2	WASHER PLAIN

F2410-0101

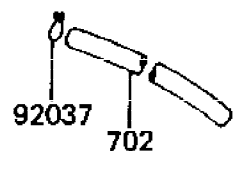
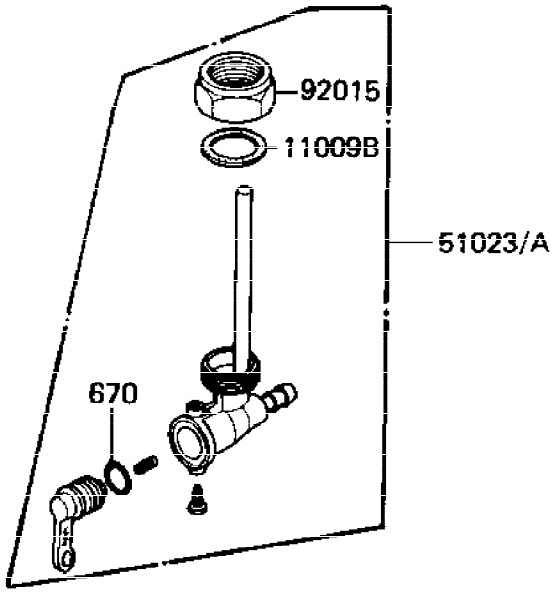
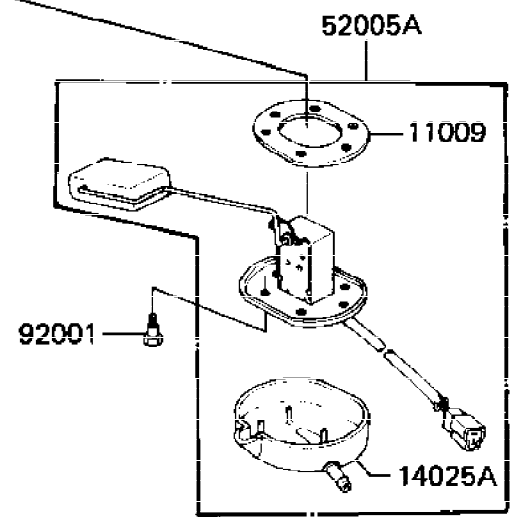
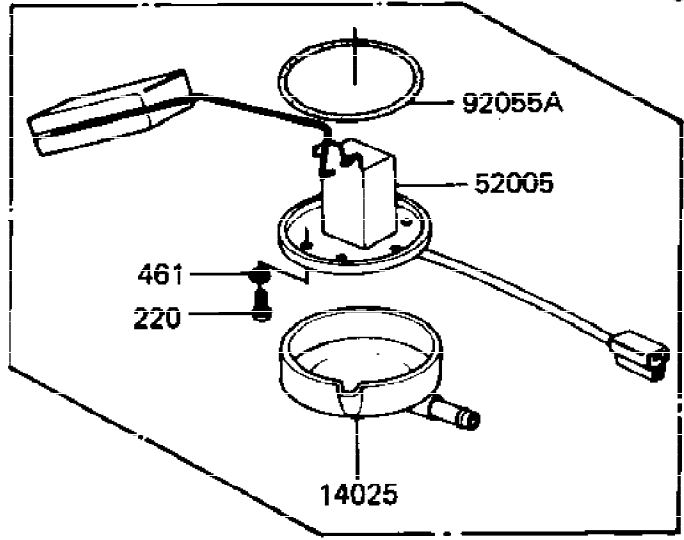
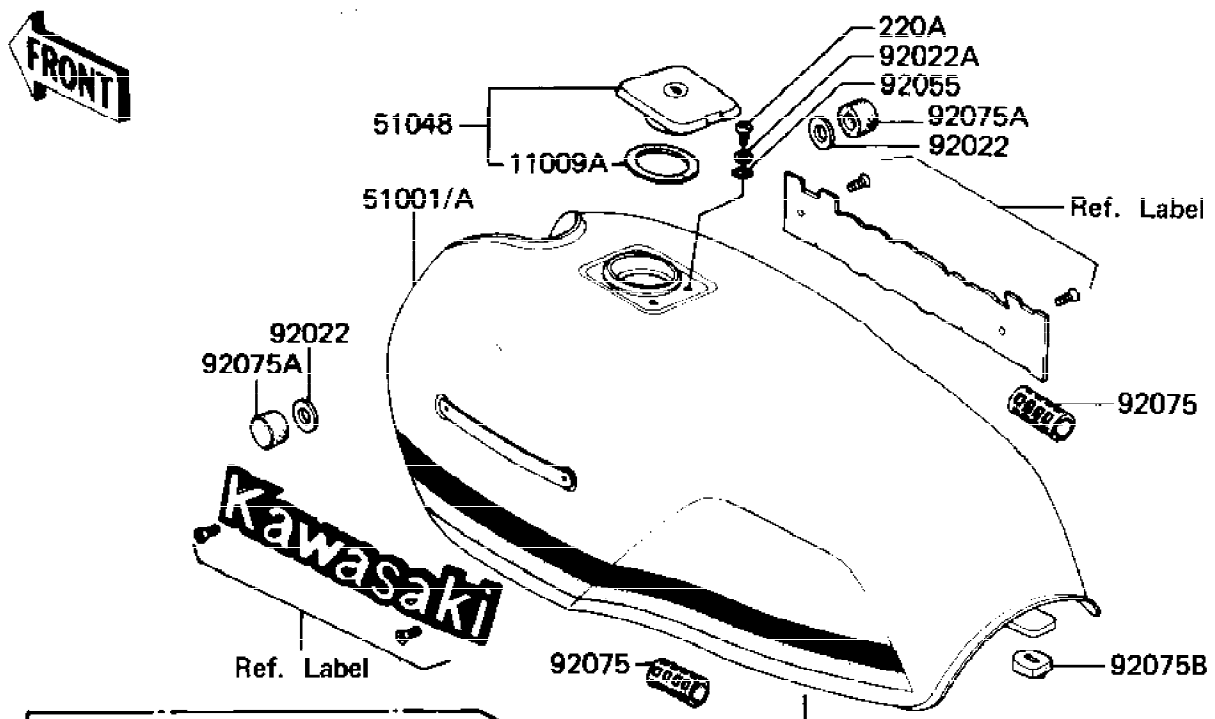

Ref #	Part Number	Qty	Description
11009	11009-1037	1	GASKET
11009A	11009-1051	1	GASKET,FUEL TANK CAP
11009B	92065-081	1	GASKET-FUEL COCK JNT.
14025	14025-1091	1	COVER,FUEL GAGE
14025A	14024-1434	1	COVER,FUEL GAUGE
51001	51001-1077-B1	1	TANK-FUEL,F.RED
51001A	51001-1095-B1	1	TANK-FUEL,F.RED
51023	51023-1007	1	TAP ASSY,FUEL
51023A	51023-1101	1	TAP-ASSY-FUEL
51048	51048-1015	1	CAP-ASSY-TANK,FUEL
52005	52005-1018	1	GAUGE,FUEL
52005A	52005-1026	1	GAUGE,FUEL
92001	92001-1069	6	BOLT,FUEL GAUGE FIT
92015	51035-009	1	FUEL COCK JOINT NUT
92022	92022-044	2	WASHER-PL-10.5X26X2.3
92022A	92022-1038	2	WASHER,PLAIN
92037	92037-147	1	CLAMP,CHAIN OILER
92055	92055-1023	2	"0" RING
92055A	92055-1067	1	"0" RING
92075	92075-084	2	DAMPER RUBBER
92075A	92075-125	2	DAMPER RUBBER,FL TANK
92075B	92075-295	1	DAMPER RUBBER FUEL TA
220	220B0508	5	SCREW PAN HEAD 5X8
220A	220B0510	2	SCREW PAN HEAD 5X10
461	461F0500	5	WASHER SPRING 5MM
670	670B2010	1	"0" RING, 10MM
702	702A071000	1	TUBE-BREATHING (BULK)



Ref #	Part Number	Qty	Description
13091	13091-1087	1	HOLDER,CHANGE DRUM PI
13091A	13091-1088	1	HOLDER,CHANGE DRUM
13140	13140-1045	2	FORK-SHIFT
13140A	13140-1046	1	FORK-SHIFT
13151	13151-5003	1	SWITCH,NEUTRAL
13239	13239-1107	1	DRUM-ASSY-CHANGE (SUBSTITUTES 13239-1054 )
13239A	13239-1107	1	DRUM-ASSY-CHANGE
14014	14014-1015	1	PLATE-POSITION
49047	49047-1019	1	ROD-SHIFT
49047A	49047-1014	1	ROD-SHIFT
92043	92042-014	5	PIN GEAR CHANGE DRUM
92043A	92042-020	1	PIN-CHANGE DRUM
92045	92045-1035	1	BEARING-BALL,6806
110	112G0616	2	BOLT-UPSET,6X16
221	221B0645	1	SCREW-CSK-CROS,6X45
480	480J1200	1	CIRCLIP 12MM
610	610A0410	1	PIN DOWEL 4X10

E1370-0064

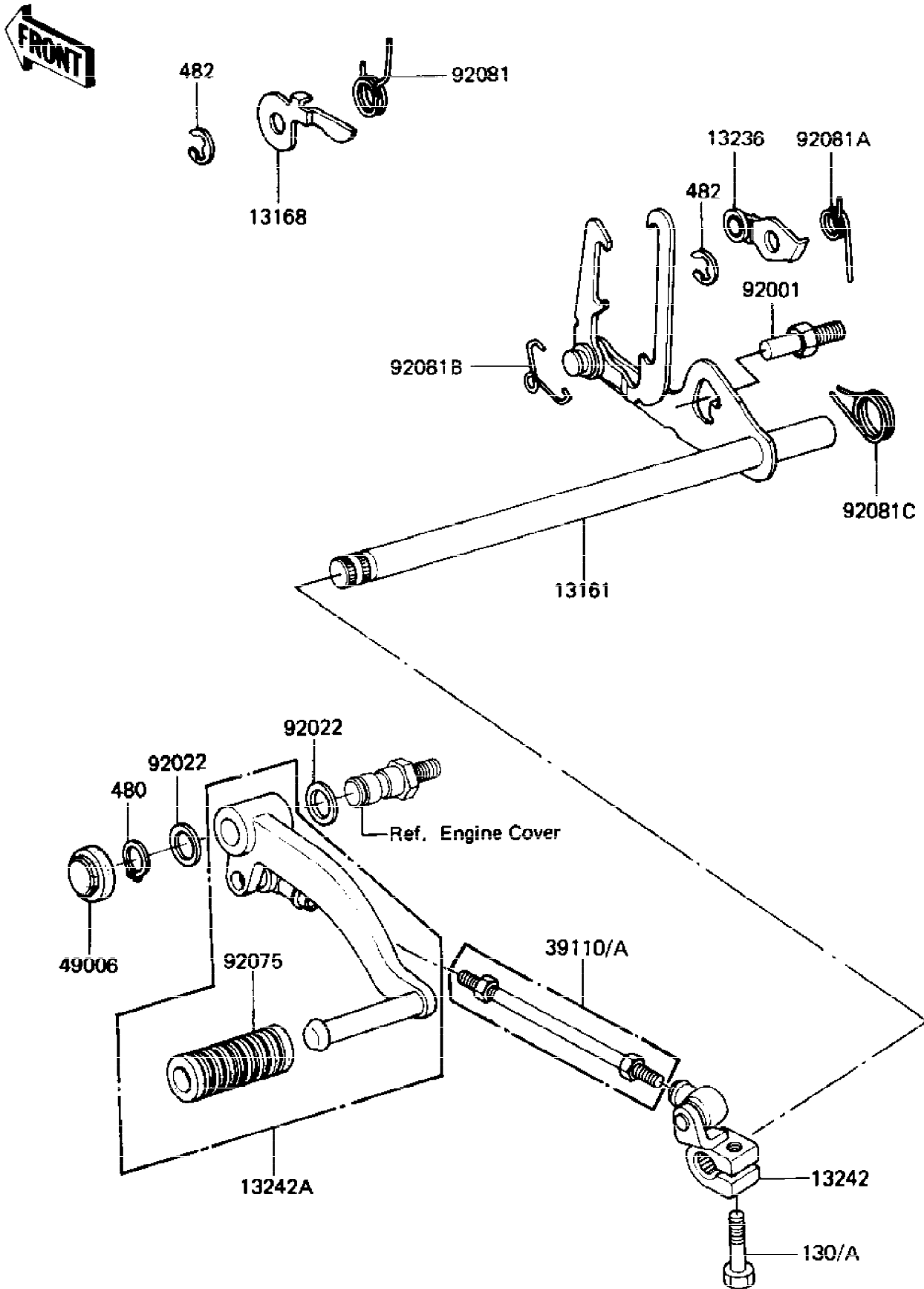

Ref #	Part Number	Qty	Description
13161	13161-1023	1	LEVER-COMP-CHANGE SHA
13168	13168-1074	1	LEVER,GEAR POSITIONIN
13236	13236-1029	1	LEVER-COMP,NEUTRAL PO
13242	13242-1048	1	LEVER-ASSY-CHANGE,ROD
13242A	13242-1049	1	LEVER-ASSY-CHANGE,PDL
39110	39110-1005	1	ROD-ASSY-TIE,L=90,BLK
39110A	39110-1008	1	ROD-ASSY-TIE,L=90,BLA
49006	49006-1061	1	BOOT,CHANGE LEVER
92001	92001-1401	1	BOLT,RETURN SPRING
92022	92022-072	2	WASHER PLAIN 12MM
92075	13157-004	1	RUBBER CHANGE PEDAL
92081	92081-1284	1	SPRING,POSITIONING LE
92081A	92081-1285	1	SPRING
92081B	92083-018	1	SPRING,KICK PAWL
92081C	92083-028	1	SPRING,CHG PEDL RTRN
130	130P0620	1	BOLT-FLANGED,6X20
130A	130S0620	1	BOLT-FLANGED,6X20,BLA
480	480J1200	1	CIRCLIP 12MM
482	482J6000	2	CIRCLIP 6MM



E1810-0009

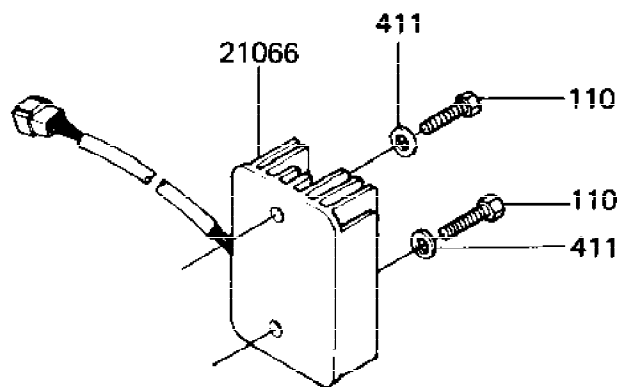
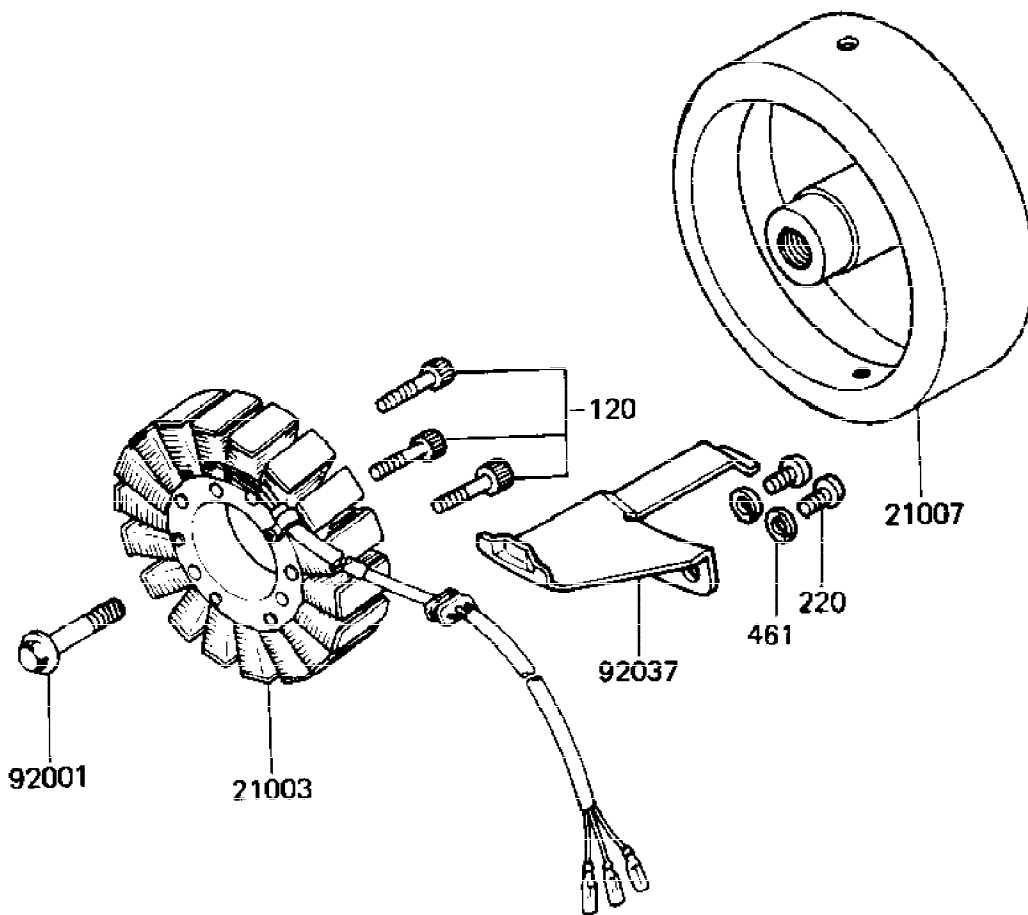

Ref #	Part Number	Qty	Description
21003	21003-1040	1	STATOR
21007	21007-1036	1	ROTOR
21066	21066-1018	1	REGULATOR-VOLTAGE
92001	92001-1146	1	BOLT,12X40
92037	92037-1214	1	CLAMP
110	112B0614	2	BOLT-UPSET 6X14
120	120P0630	3	BOLT,SOCKET,6X30
220	220B0512	2	SCREW PAN HEAD 5X12
411	411B0600	2	WASHER PLAIN 6MM
461	461F0500	2	WASHER SPRING 5MM

F2310-0147

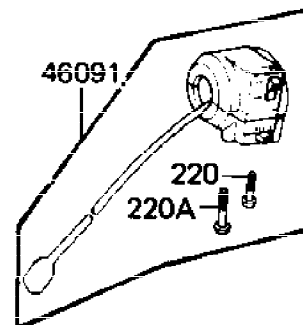
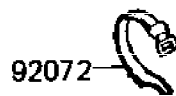
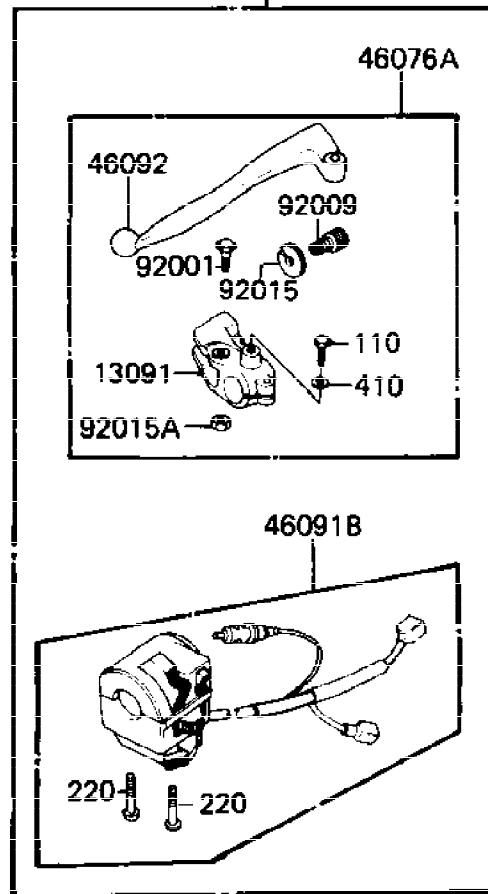
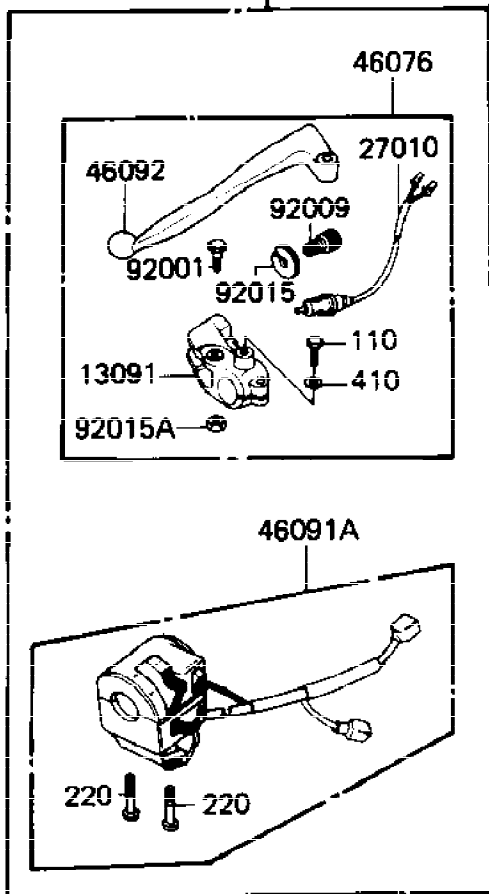
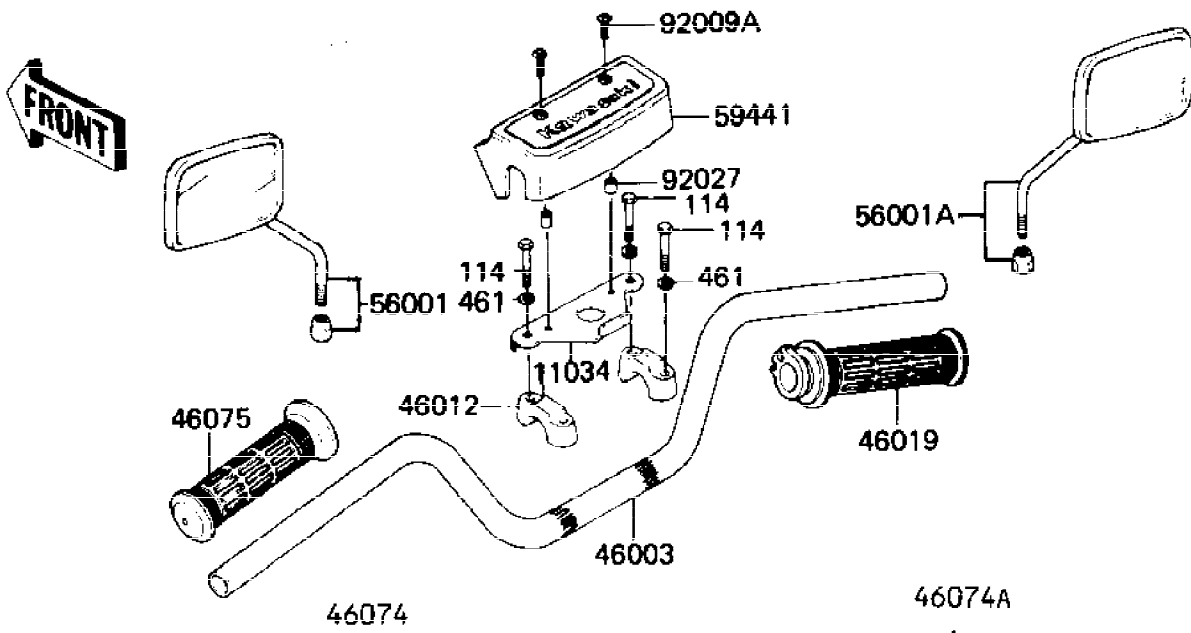

Ref #	Part Number	Qty	Description
11034	11034-1899	1	BRACKET,HANDLE COVER
13091	13091-1046	2	HOLDER,CLUTCH LEVER
27010	27010-1045	1	SWITCH,CLUTCH
46003	46003-1079	1	HANDLEBAR
46012	46012-1011	2	HOLDER-HANDLE
46019	46019-1015	1	GRIP-ASSY,THROTTLE
46075	46075-1022	2	GRIP,LH
46076	46076-1012	1	LEVER-ASSY-GRIP,LH
46076A	46076-1020	1	LEVER-ASSY-GRIP,CLTCH
46091	46091-1155	1	HOUSING-ASSY-CNTRL,RH
46091A	46091-1180	1	HOUSING-ASSY-CNTRL,LH
46091B	46091-1180	1	HOUSING-ASSY-CNTRL,LH
46092	46092-1020	2	LEVER-GRIP,RH
56001	56001-1097	1	MIRROR-ASSY,LH
56001A	56001-1098	1	MIRROR-ASSY,RH
59441	59441-1001	2	COVER-HANDLE
92001	92001-1075	2	BOLT,CLUTCH LEVER FIT
92009	46055-003	2	SCREW CABLE ADJUST
92009A	92009-1108	2	SCREW,4X16
92015	46056-005	2	NUT-LOCK
92015A	92019-008	2	NUT
92027	92027-1313	2	COLLAR,4.5X6.5X9.3
92072	92072-030	4	BAND,SHORT
1110	110N0622	2	BOLT, HEX HEAD 6X22
1114	115G0835	4	BOLT,SMALL UPSET
220	220B05354	5	UNAVAILABLE IN PRICE BOOK
220A	220B0540	1	SCREW-PAN-CROS
410	410B0600	2	WASHER PLAIN 6MM
461	461F0800	4	WASHER SPRING 8MM

F2310-0148

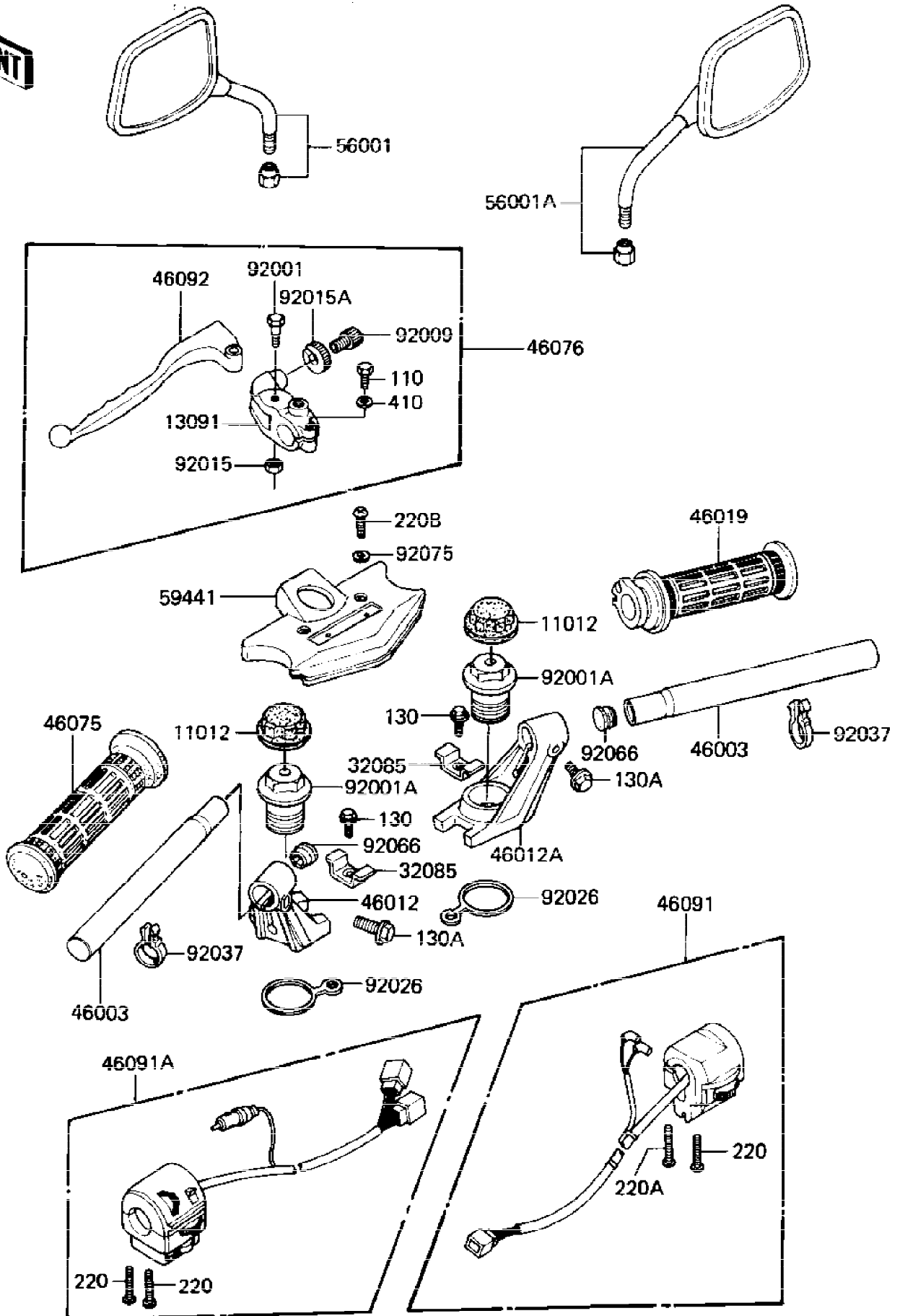

Ref #	Part Number	Qty	Description
11012	11012-1250	2	CAP,BOLT,PP,BLACK
13091	13091-1046	1	HOLDER,CLUTCH LEVER
32085	32085-1092	2	STOPPER
46003	46003-1094	2	HANDLEBAR
46012	46012-1022	1	HOLDER-HANDLE,LH
46012A	46012-1023	1	HOLDER-HANDLE,RH
46019	46019-1015	1	GRIP-ASSY,THROTTLE
46075	46075-1022	1	GRIP,LH
46076	46076-1026	1	LEVER-ASSY-GRIP,CLUTC
46091	46091-1214	1	HOUSING-ASSY-CNTRL,RH
46091A	46091-1228	1	HOUSING-ASSY-CNTRL,LH
46092	46092-1024	1	LEVER-GRIP,CLUTCH
56001	56001-1352	1	MIRROR-ASSY,LH
56001A	56001-1353	1	MIRROR-ASSY,RH
59441	59441-1004	1	COVER-HANDLE
92001	92001-1548	1	BOLT,CLUTCH LEVER,BLA
92001A	92001-1563	2	BOLT,FLANGED,34X40,BL
92009	92009-1134	1	SCREW,CABLE ADJUST,8
92015	92015-1191	1	NUT,LOCK,6MM,BLACK
92015A	92015-1197	1	NUT,CABLE ADJUST LOCK
92026	92026-1116	2	SPACER,HANDLE HOLDER
92037	92037-1334	2	CLAMP,ID=16,PP
92066	92066-1093	2	PLUG,HANDLE
92075	23058-002	2	WASHER-PLAIN,4MM
110	110C0622	1	BOLT,6X22,BLACK
130	130J0616	2	BOLT-FLANGED,6X16
130A	130S0825	2	BOLT-FLANGED,8X25,BLA
220	220B0535	3	SCREW-PAN-CROS
220A	220B0540	1	SCREW-PAN-CROS
220B	220C0430	2	SCREW-PAN-CROS



Ref #	Part Number	Qty	Description
11034	11034-1937	1	BRACKET,HEAD LAMP
11036	11036-1059	1	BRACKET-A,HEAD LAMP
13091	13091-1035	1	HOLDER,HEAD LAMP MOUN
13091A	13091-1036	1	HOLDER,HEAD LAMP SOCK
14020	14020-1005	1	RETAINER,HEAD LAMP
23004	23004-1075	1	LAMP-HEAD
23005	23005-1024-21	1	BODY-COMP-HEAD LAMP,F
23006	23006-1005	1	RIM,HEAD LAMP
23007	23007-1013	1	LENS UNIT,HEAD LAMP
49016	49016-1023	1	COVER,HEAD LAMP SOCKE
92001	92001-1405	2	BOLT 8X38
92009	23019-023	2	SCREW-PAN HEAD,5X12
92009A	92009-1047	1	SCREW,HEAD LAMP LENS
92009B	92011-024	2	SCREW-PAN HEAD,5MM
92015	23020-018	1	NUT,4MM
92015A	23020-023	1	NUT,HEAD LAMP RIM FIT
92015B	92015-1014	2	NUT,8M/M
92015C	92015-1050	1	NUT,HEAD LAMP BODY FT
92015D	92015-1078	1	NUT-6MM
92022	23021-004	1	WASHER
92022A	23021-010	2	WASHER
92022B	23021-012	2	WASHER-PLAIN,5MM
92022C	92022-125	3	WASHER 6.5X20X1.6T
92027	92027-1131	2	COLLAR,HEAD LAMP FITT
92027A	92027-162	3	COLLAR,REAR FENDER
92069	92069-1002	1	BULB,12V-60/55W
92075	92075-1109	2	DAMPER,HEAD LAMP FITT
92075A	92075-1110	2	DAMPER,HEAD LAMP FITT
92075B	92075-1243	2	DAMPER RUBBER
92075C	92075-209	3	DAMPER RUBBER,RR FENR
92081	92081-1103	1	SPRING,HEAD LAMP LENS
110	112G0612	1	BOLT-UPSET,6X12
110A	112B0614	1	BOLT-UPSET 6X14
110B	112G0625	3	BOLT-UPSET
220	220B0308	4	SCREW PAN HEAD 3X8
411	411B0600	1	WASHER PLAIN 6MM
411A	411D0800	2	WASHER,PLAIN,8MM
461	461F0500	2	WASHER SPRING 5MM
461A	461F0600	4	WASHER SPRING 6MM



F2710-0106

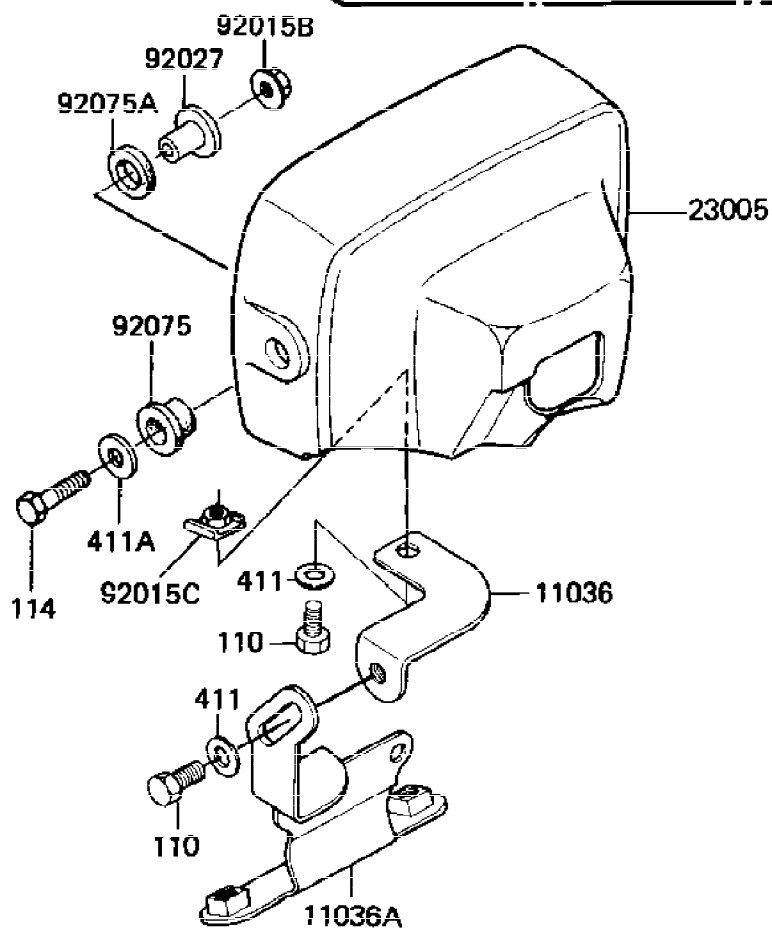
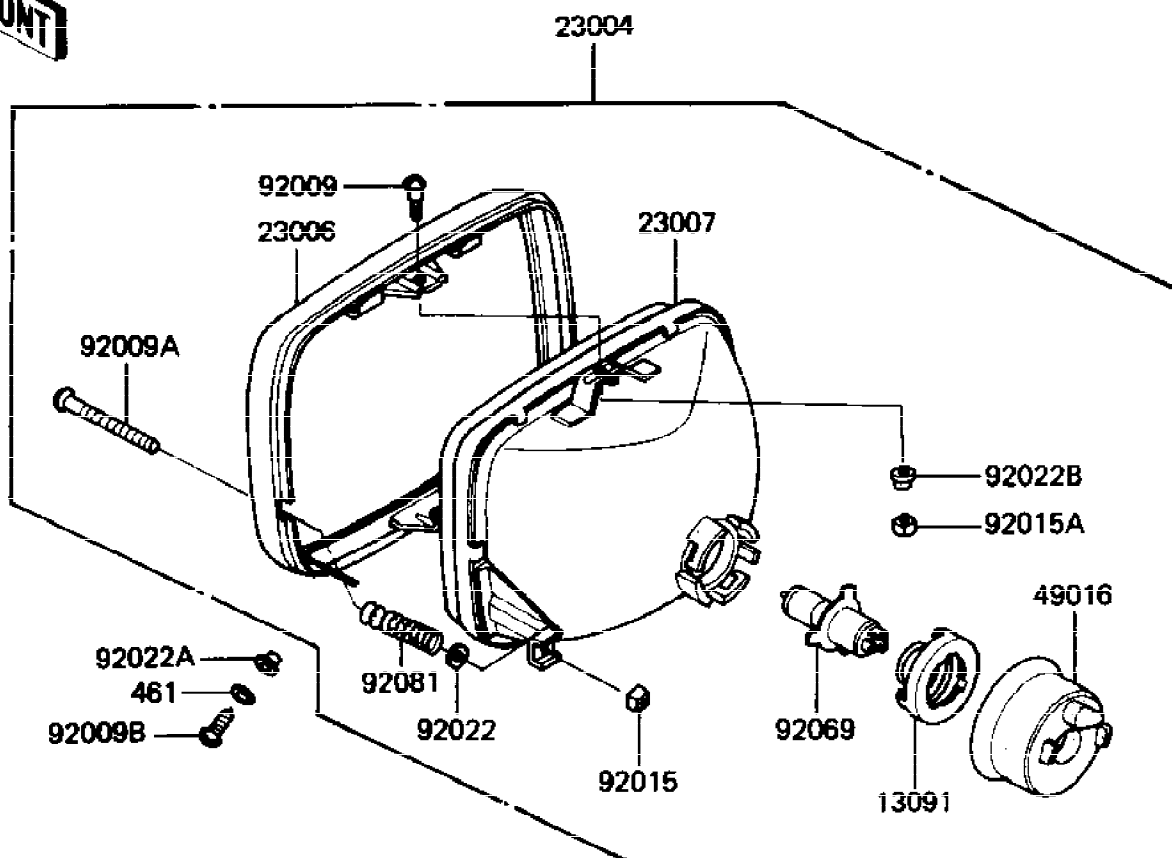

Ref #	Part Number	Qty	Description
11036	11036-1354	1	BRACKET-A,HEAD LAMP,B
11036A	11036-1355	1	BRACKET-A,HEAD LAMP,B
13091	13091-1036	1	HOLDER,HEAD LAMP SOCK
23004	23004-1116	1	LAMP-HEAD
23005	23005-1022-6Z	1	BODY-COMP-HEAD LAMP
23006	23006-1024	1	RIM-LAMP,BLACK
23007	23007-1041	1	LENS-COMP
49016	49016-1023	1	COVER,HEAD LAMP SOCKE
92009	23019-023	2	SCREW-PAN HEAD,5X12
92009A	92009-1047	1	SCREW,HEAD LAMP LENS
92009B	92011-024	2	SCREW-PAN HEAD,5MM
92015	23020-018	1	NUT,4MM
92015A	23020-023	2	NUT,HEAD LAMP RIM FIT
92015B	92015-1014	2	NUT,8M/M
92015C	92015-1050	1	NUT,HEAD LAMP BODY FT
92022	23021-004	1	WASHER
92022A	23021-010	2	WASHER
92022B	23021-012	2	WASHER-PLAIN,5MM
92027	92027-1131	2	COLLAR,HEAD LAMP FITT
92069	92069-1002	1	BULB,12V-60/55W
92075	92075-1109	2	DAMPER,HEAD LAMP FITT
92075A	92075-1110	2	DAMPER,HEAD LAMP FITT
92081	92081-1103	1	SPRING,HEAD LAMP LENS
1110	112B0614	2	BOLT-UPSET 6X14
1114	115C0835	2	BOLT-SMALL-UPSET
411	411B0600	2	WASHER PLAIN 6MM
411A	411F0800	2	WASHER PLAIN
461	461F0500	2	WASHER SPRING 5MM

E1830-0080

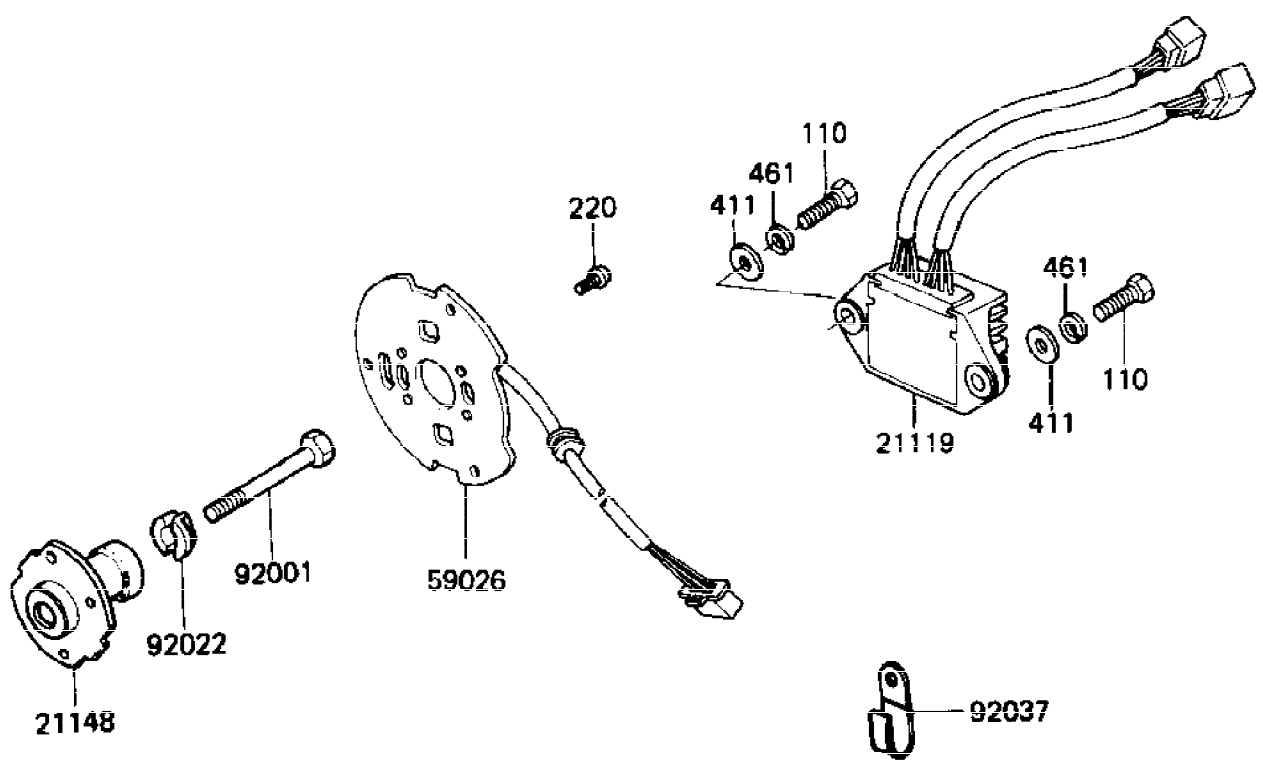
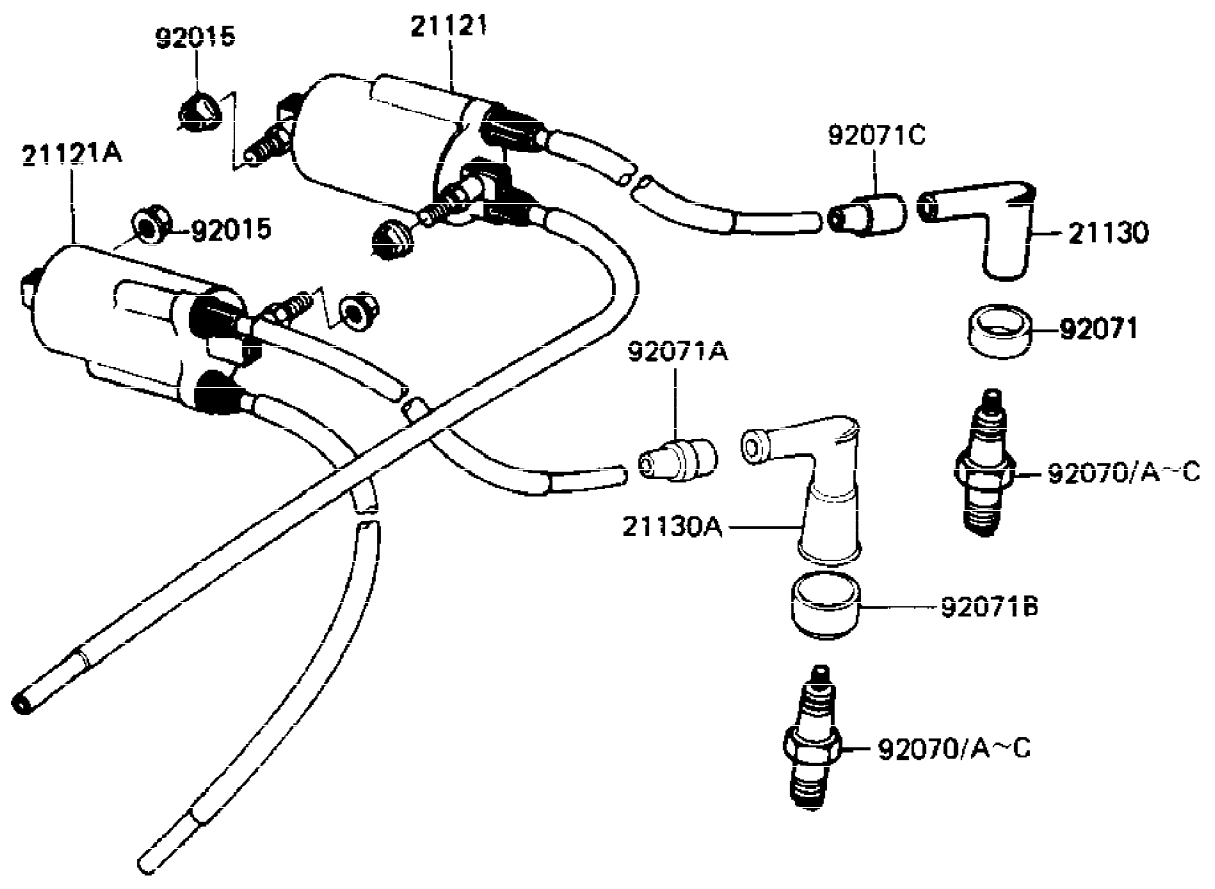

Ref #	Part Number	Qty	Description
21119	21119-1041	1	IGNITER
21121	21121-1038	1	COIL-IGNITION
21121A	21121-1039	1	COIL-IGNITION
21130	21130-1007	2	CAP-SPARK PLUG,RTFM20
21130A	21130-1010	2	CAP-SPARK PLUG
21148	21148-1020	1	GOVERNOR-BREAKER
59026	59026-1012	1	COIL-PULSING
92001	92001-1397	1	BOLT-8X63
92015	92015-1078	4	NUT-6MM
92022	92022-244	1	WASHER,SPARK ADVANCER
92037	21126-008	4	CLAMP,WIRING HARNESS
92070	B8ES	4	SPARK PLUG B8ES US
92070B	BR8ES	4	SPARK PLUG BR8ES CN
92071	21131-004	2	GROMMET-PLUG CAP,A
92071A	21131-005	2	GROMMET,HIGH TENSION
92071B	21131-006	2	GROMMET,PLUG CAP
92071C	21132-005	2	GROMMET,SPARK PLG CAP
110	112G0618	2	BOLT-UPSET
220	220B0512	3	SCREW PAN HEAD 5X12
411	411B0600	2	WASHER PLAIN 6MM
461	461F0600	2	WASHER SPRING 6MM



Attached two keys only

F2770-0116

27008

27004/A

For P/No. 27004-5098 For P/No. 27004-5158

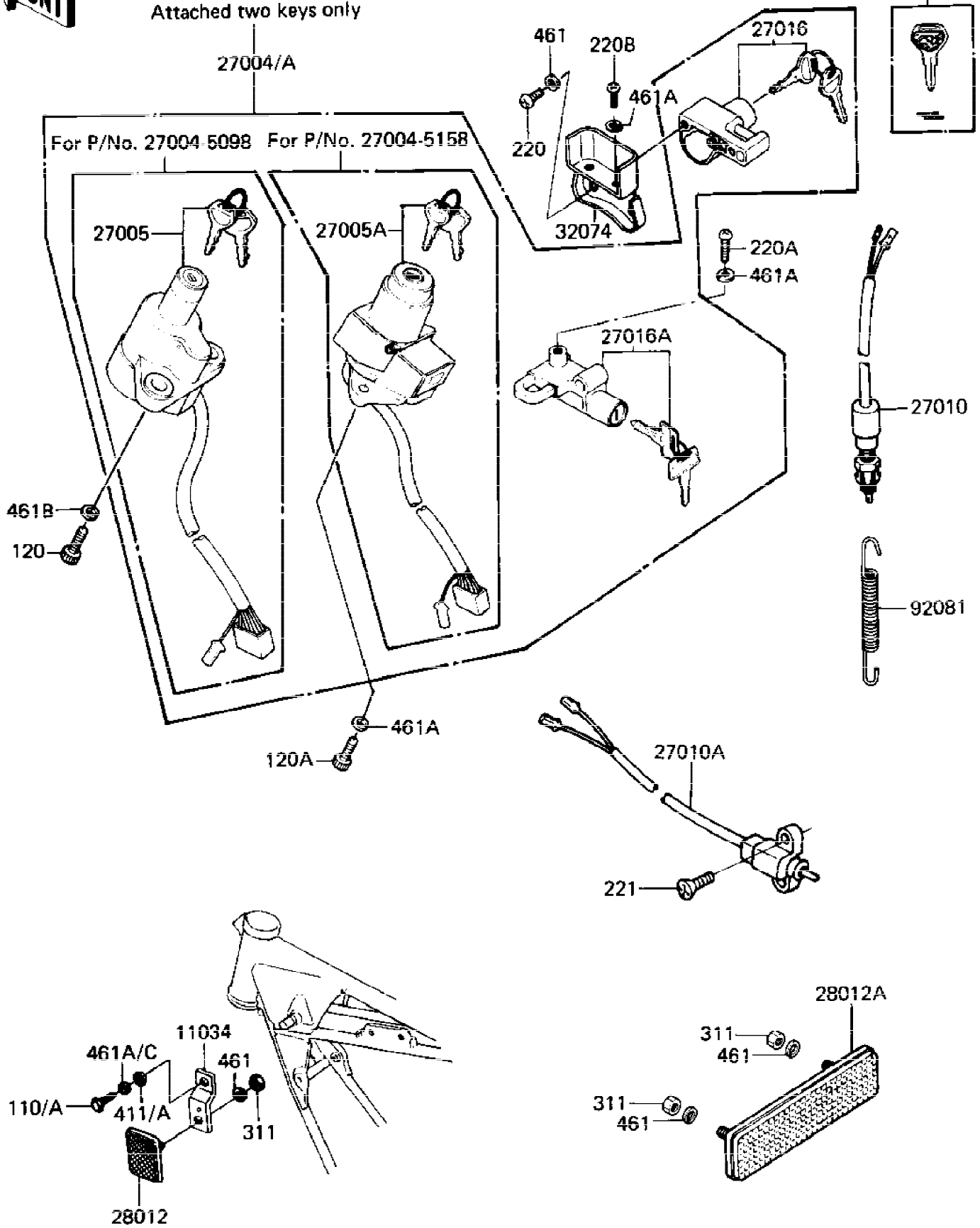

## IGNITION SWITCH/LOCKS/REFLECTORS

Ref #	Part Number	Qty	Description
11034	11034-1929	2	BRACKET
27004	27004-5098	1	SWITCH-ASSY
27004A	27004-5205	1	SWITCH-ASSY,ALL
27005	27005-5019	1	SWITCH-ASSY-IGNITION
27005A	27005-5035	1	SWITCH-ASSY-IGNITION
27008	27008-1103	1	KEY-LOCK,BLANK (OPTION)
27010	27010-1019	1	SWITCH,BRAKE LAMP
27010A	27010-1065	1	SWITCH,SIDE STAND
27016	27016-5070	1	LOCK-ASSY,HELMET
27016A	27016-5069	1	LOCK-ASSY,SEAT
28012	28012-1003	2	REFLECTOR,REFLEX(FRON
28012A	28012-1005	1	REFLECTOR,REAR REFLEX
32074	32074-1024	1	BRACKET-LOCK,HELMET L
92081	92081-1366	1	SPRING,BRAKE SWITCH
110	112B0614	2	BOLT-UPSET 6X14
110A	112C0614	2	BOLT, 6X14, BLACK
120	120P0822	2	BOLT,SOCKET,8X22
120A	120S0616	2	BOLT-SOCKET,6X16,BLAC
220	220B0508	2	SCREW PAN HEAD 5X8
220A	220B0610	1	SCREW PAN HEAD 6X10
220B	220B0612	2	SCREW PAN HEAD 6X12
221	221C0520	2	SCREW-CSK-CROS
311	311B0500	4	NUT,5MM
411	411B0600	2	WASHER PLAIN 6MM
411A	411F0600	2	WASHER PLAIN
461	461F0500	6	WASHER SPRING 5MM
461A	461F0600	5	WASHER SPRING 6MM
461B	461F0800	2	WASHER SPRING 8MM
461C	461K0600	2	WASHER-SPRING,6MM,BLA

F1530-0002

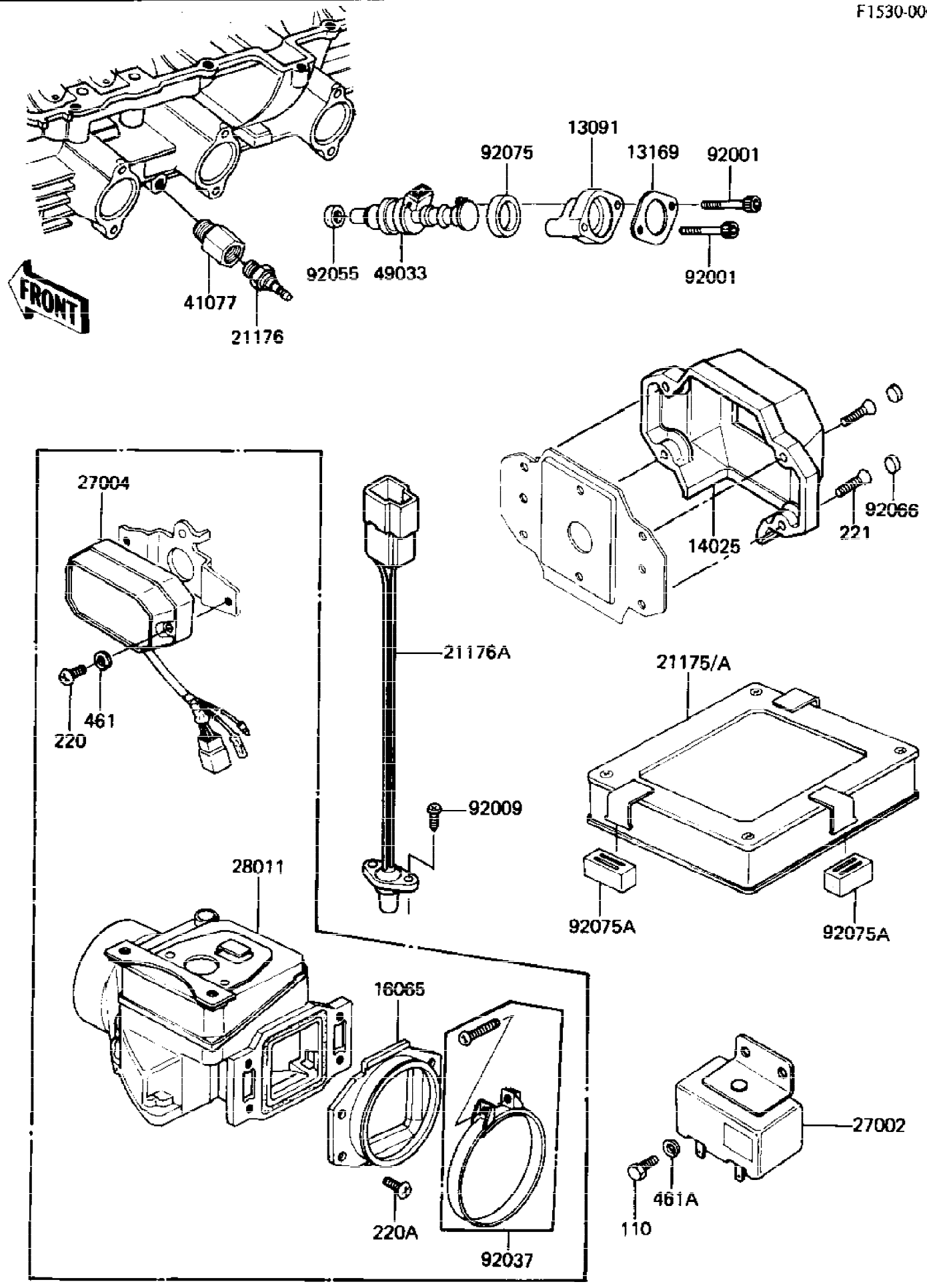

Ref #	Part Number	Qty	Description
13091	13091-1092	4	HOLDER,FUEL INJECTOR
13169	13169-1434	4	PLATE,FUEL INJECTOR,B
14025	14025-1446	1	COVER,THROTTLE SENSOR
16065	16065-1038	1	HOLDER,AIR FLOW METER
21175	21175-1003	1	CONTROL UNIT-ELECTRON
21175A	21175-1004	1	CONTROL UNIT-ELECTRON
21176	21176-1002	1	SENSOR-TEMPERATURE
21176A	21176-1003	1	SENSOR,AIR-TEMPERATUR
27002	27002-1007	1	RELAY ASSY
27004	27004-1009	1	SWITCH-ASSY,THROTTLE
28011	28011-1010	1	METER,AIR FLOW
41077	41077-1004	1	ADAPTER,SENSOR
49033	49033-1001	4	INJECTOR,FUEL
92001	120S0540	8	BOLT-SOCKET
92009	92009-1028	2	SCREW,TAPPING,3X12,BL
92037	92037-1237	1	CLAMP,ID=80
92055	92055-1082	4	INSULATOR,FUEL INJECT
92066	92066-1107	4	PLUG,THR SENSOR COVER US
92075	92075-1240	4	INSULATOR,FUEL INJECT
92075A	92075-1312	3	DAMPER,CONTROL UNIT
110	112G0612	2	BOLT-UPSET,6X12
220	220B0412	2	SCREW-PAN-CRROSS,4X12
220A	220B0612	4	SCREW PAN HEAD 6X12
221	221C0310	4	SCREW-CSK-CROS
461	461F0400	2	WASHER SPRING 4MM
461A	461F0600	2	WASHER SPRING 6MM



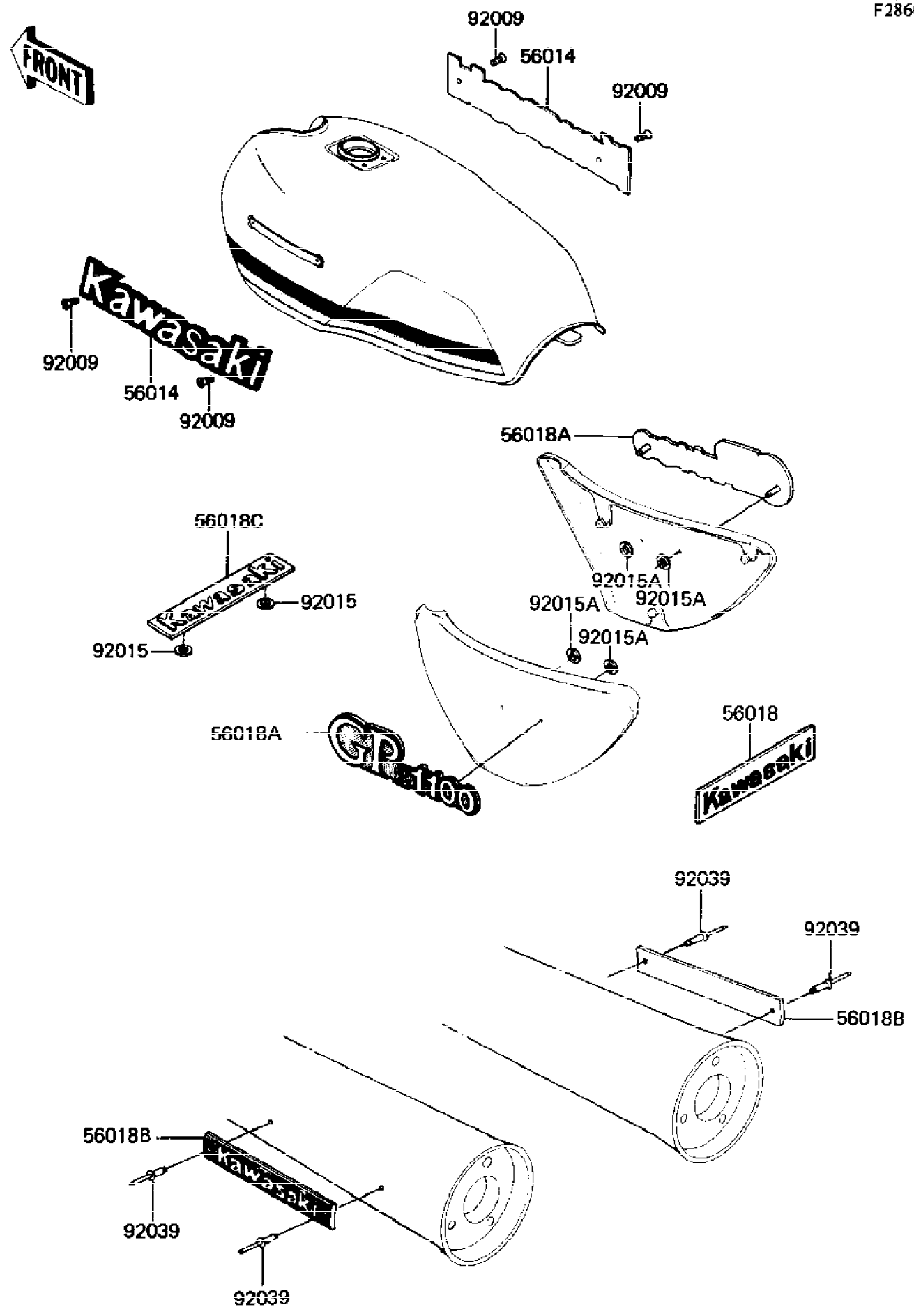

Ref #	Part Number	Qty	Description
56014	56014-1043	2	EMBLEM,FUEL TANK
56018	56018-1208	1	MARK,SEAT COVER
56018A	56018-1247	2	MARK,SD COVER,GPZ1100
56018B	56018-1419	2	MARK,MUFFLER,KAWASAKI
56018C	56018-1297	1	MARK,HANDLE COVER,KAW
92009	221C0306	4	SCREW-CSK-CROS
92015	92015-1202	2	NUT,PUSH,2MM
92015A	92018-005	4	NUT,LOCK,3MM
92039	92039-1030	4	RIVET,BLIND,1.93X26,B

F2530-0041

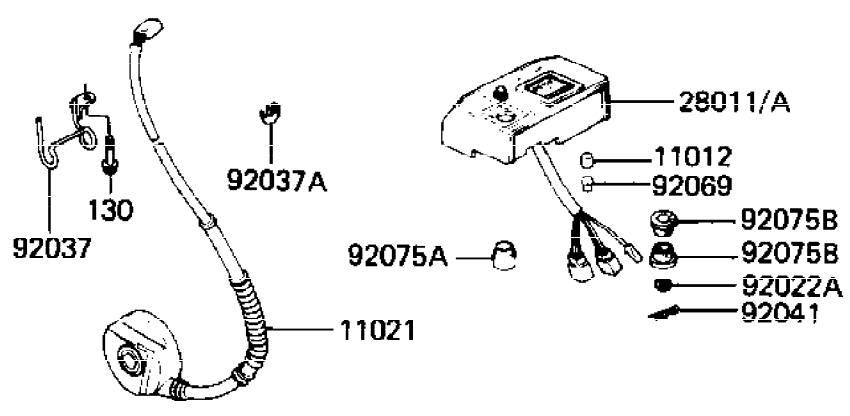
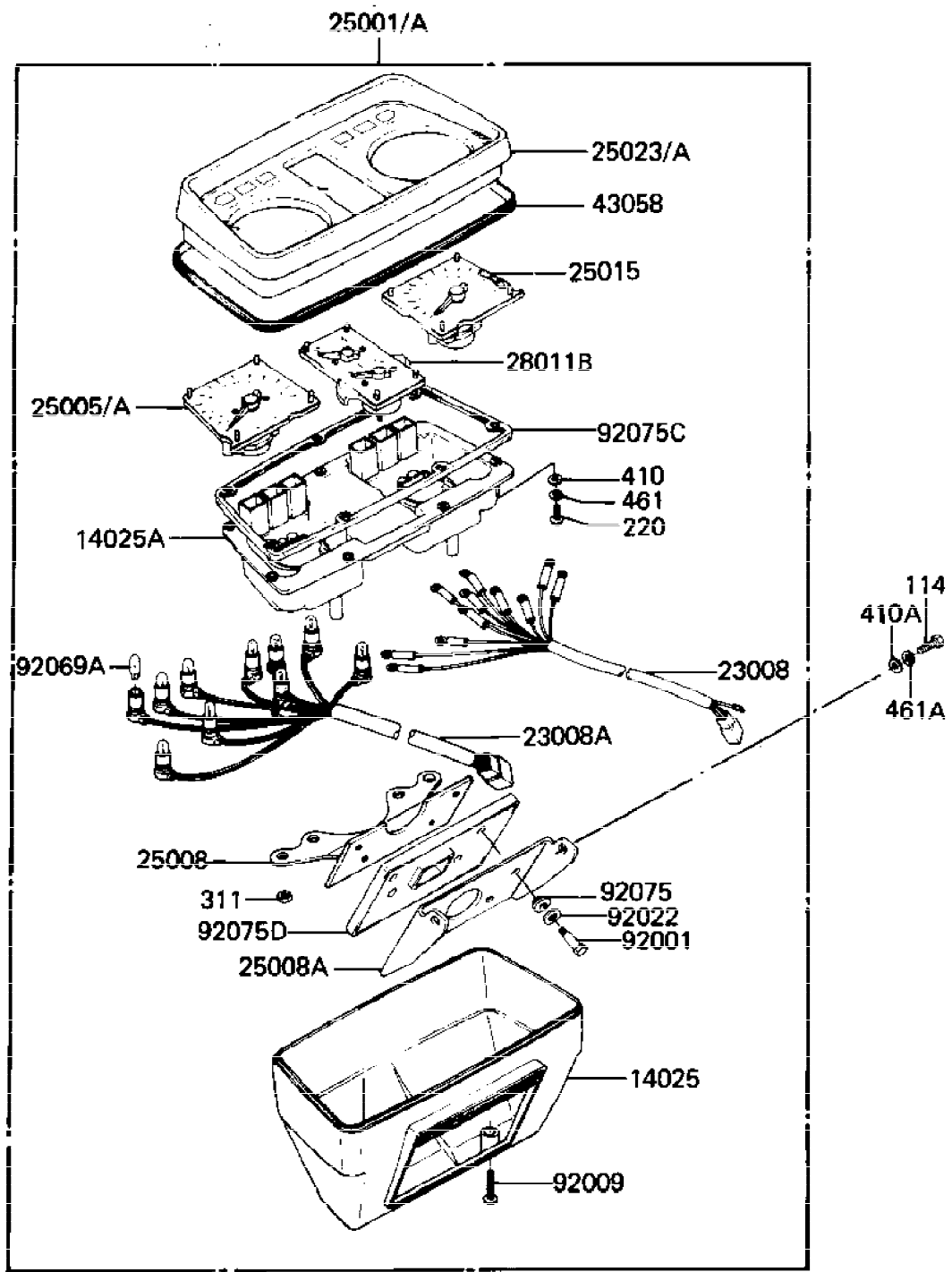

Ref #	Part Number	Qty	Description
11012	11012-1172	1	CAP,BULB,GREEN
11021	11021-1011	1	CASE-ASSY
14025	14025-1384	1	COVER,METER CASE,LWR
14025A	14025-1526	1	COVER,METER HOUSING
23008	23008-1112	1	SOCKET-ASSY,METER UNT
23008A	23008-1113	1	SOCKET-ASSY,METER LMP
25001	25001-1218	1	METER-ASSY,MPH US
25001A	25001-1219	1	METER-ASSY,KPH (Canada) CN
25005	25005-1128	1	SPEEDOMETER,MPH US
25005A	25005-1129	1	SPEEDOMETER,KPH (Canada) CN
25008	25008-1043	1	BRACKET-METER,CASE
25008A	25008-1044	1	BRACKET-METER,COVER
25015	25015-1092	1	TACHOMETER,X1000RPM
25023	25023-1030	1	COVER-METER CASE,UPP CN
25023A	25023-1031	1	COVER-METER CASE,UPP US
28011	28011-1011	1	METER,TOTAL & TRIP US
28011A	28011-1012	1	METER,TOTAL & TRIP (Canada) CN
28011B	28011-1026	1	METER-FUEL & VOLT
43058	43058-1022	1	RING-METER CASE COVER
92001	92001-1477	4	BOLT,5MM,BLACK
92009	92009-1125	2	SCREW,4X25,BLACK
92022	92022-1273	4	WASHER,7.2X15X1,BLACK
92022A	92022-263	2	WASHER,PLAIN,6MM
92037	92037-1230	1	CLAMP
92037A	92037-1249	3	CLAMP,CASE ASSY,WIRE
92041	92041-006	2	PIN,COTER
92069	92069-017	1	BULB 12V 1.5W
92069A	92069-1007	10	BULB,12V3.4W
92075	25019-023	4	DAMPER RUBBER,MET FIT
92075A	92075-1286	1	DAMPER
92075B	92075-1300	4	DAMPER,TRIP METER
92075C	92075-1341	1	DAMPER,WATERPROOF PRT
92075D	92075-1342	1	DAMPER,WATERPROOF PRT
114	115G0818	2	BOLT-SMALL-UPSET,8X18
130	130B0608	1	BOLT,FLANGED,6X8
220	220B0410	7	SCREW PAN HEAD 4X10
311	311B0500	4	NUT,5MM
410	410B0400	7	WASHER PLAIN 4MM
410A	410B0800	2	WASHER PLAIN 8MM
461	461F0400	7	WASHER SPRING 4MM
461A	461F0800	2	WASHER SPRING 8MM



F2530-0126

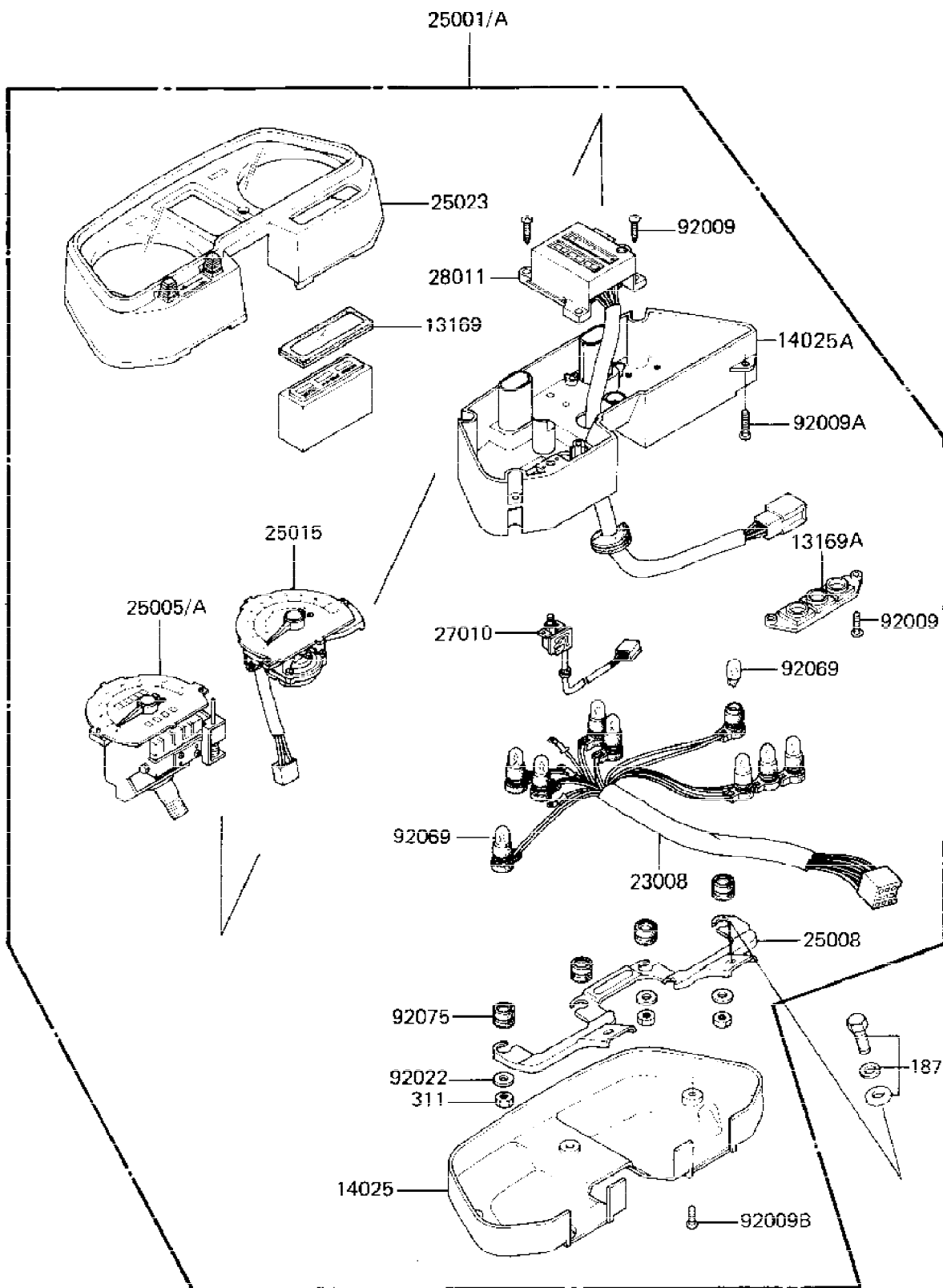

Ref #	Part Number	Qty	Description
13169	13169-1508	1	PLATE,PILOT BOX
13169A	13169-1556	1	PLATE,BULB SOCKET
14025	14025-1473	1	COVER,METER,LWR
14025A	14025-1951	1	COVER,METER UNIT
23008	23008-1149	1	SOCKET-ASSY,METER
25001	25001-1315	1	METER-ASSY,MPH US
25001A	25001-1316	1	METER-ASSY,KPH (Canada) CN
25005	25005-1175	1	SPEEDOMETER,MPH US
25005A	25005-1180	1	SPEEDOMETER,KPH (Canada) CN
25008	25008-1057	1	BRACKET-METER CN
25015	25015-1232	1	TACHOMETER,X1000R/MIN
25023	25023-1124	1	COVER-METER CASE,UPP
27010	27010-1062	1	SWITCH,TACHO/VOLT
28011	28011-1029	1	METER,FUEL & WARNING
92009	92009-1140	4	SCREW,TAPPING,4X14
92009A	92009-1141	4	SCREW,TAPPING,4X20
92009B	92009-1142	3	SCREW,TAPPING,4X12
92022	92022-263	4	WASHER,PLAIN,6MM
92069	92069-1007	9	BULB,12V3.4W
92075	92075-1385	4	DAMPER,METER BRACKET
187	187B0614	2	BOLT 6X14
311	311B0500	4	NUT,5MM

E1140-0092

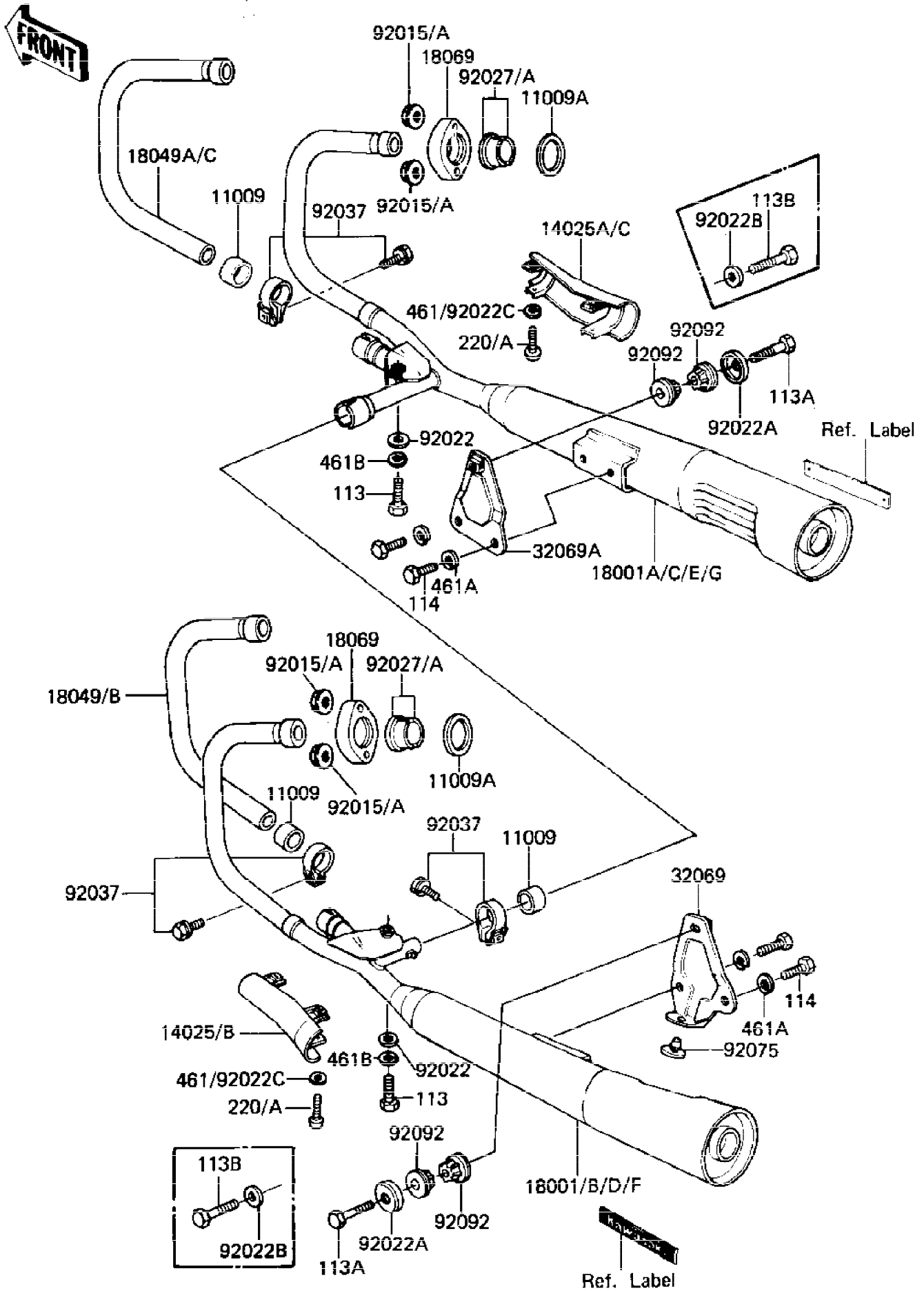

Ref #	Part Number	Qty	Description
11009	11060-1068	3	GASKET,MANIFOLD EXHAU
11009A	11009-1906	4	GASKET,EXHAUST PIPE H
14025	14025-1353	1	COVER,MUFFLER,LH,BLCK
14025A	14025-1354	1	COVER,MUFFLER,RH,BLCK
14025B	14025-1397	1	COVER,MUFFLER,LH,BLAC
14025C	14025-1398	1	COVER,MUFFLER,RH,BLAC
18001	18001-1318	1	MUFFLER,LH,BLACK US
18001A	18001-1319	1	MUFFLER,RH,BLACK US
18001B	18001-1236	1	18001-1320 (Canada) CN
18001C	18001-1237	1	18001-1321 (Canada) CN
18001D	18001-1263	1	18001-1320 (Canada) CN
18001E	18001-1264	1	18001-1321 (Canada) CN
18001F	18001-5082	1	MUFFLER,LH,F.BLACK
18001G	18001-5083	1	MUFFLER,RH,F.BLACK
18049	18049-1196	1	PIPE-EXHAUST,#2,BLACK
18049A	18049-1197	1	PIPE-EXHAUST,#3,BLACK
18049B	18049-1192	1	PIPE-EXHAUST,#2,BLACK
18049C	18049-1193	1	PIPE-EXHAUST,#3,BLACK
18069	18069-1049	4	UNAVAILABLE IN PRICE BOOK
32069	32069-1066	1	BRACKET-MUFFLER,LH
32069A	32069-1067	1	BRACKET-MUFFLER,RH
92015	92015-1143	8	NUT-8MM
92015A	92015-1174	8	NUT,CAP,8MM,BLACK
92022	92022-1022	2	WASHER,PLAIN
92022A	92022-1313	2	WASHER,CUP TYPE,BLACK
920223	92022-289	2	WASHER,PLAIN
92022C	461K0600	4	WASHER-SPRING,6MM,BLA
92027	92027-1300	8	COLLAR,EXHAUST PIPE
92027A	92027-1457	8	COLLAR,EXHAUST PIPE,B
92037	92037-1270	3	CLAMP,MUFFLER,BLACK
92075	92075-015	1	DAMPER RUBB MAIN STAD
92092	92092-4013	4	UNAVAILABLE IN PRICE BOOK
1113	11381080	2	UNAVAILABLE IN PRICE BOOK
1113A	113J1055	2	BOLT-SMALL-FINE,10X55
1113B	113N1055	2	BOLT-HEX HEAD,10X55
1114	115G0816	4	BOLT-SMALL-UPSET,8X16
220	220B0645	4	SCREW PAN HEAD 6X45
220A	220C0645	4	SCREW-PAN-CROS,6X45,B
461	461F0600	4	WASHER SPRING 6MM
461A	461F0800	4	WASHER SPRING 8MM
461B	461F1000	2	WASHER SPRING 10MM



E3034-0001

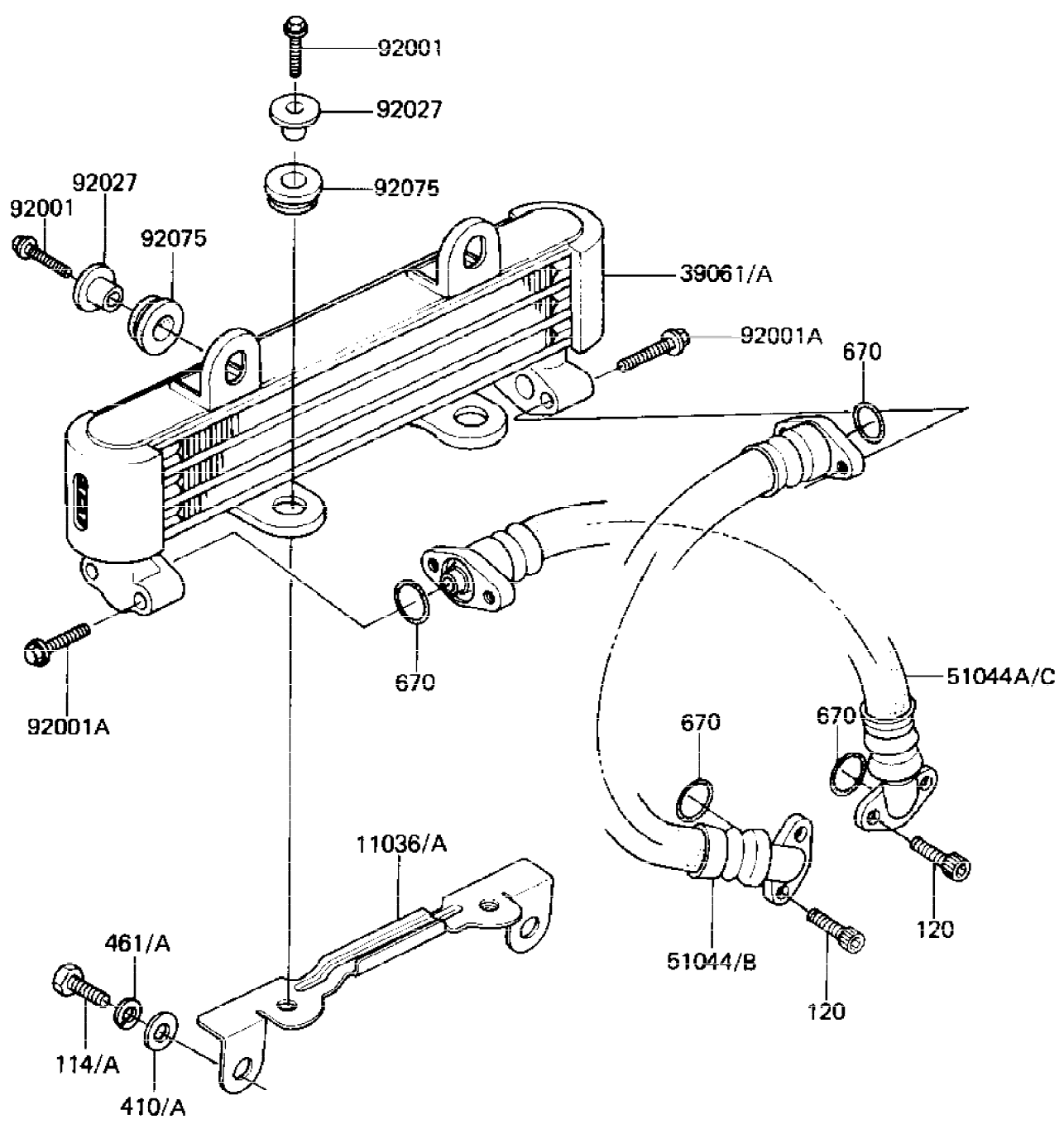

Ref #	Part Number	Qty	Description
11036	11036-1160	1	BRACKET-A,OIL COOLER
11036A	11036-1508	1	BRACKET-A,OIL COOLER
39061	39061-1006-10	1	EXCHANGER-ASSY-HEAT
39061A	39061-1006-10	1	EXCHANGER-ASSY-HEAT
51044	51044-1030	1	TUBE-ASSY,OIL COOLER
51044A	51044-1031	1	TUBE-ASSY,OIL COOLER
51044B	51044-1030	1	TUBE-ASSY,OIL COOLER
51044C	51044-1031	1	TUBE-ASSY,OIL COOLER
92001	130J0620	4	BOLT-FLANGED,6X20
92001A	92001-1467	4	BOLT,FLANGED,6X25,BLK
92027	92027-1651	4	COLLAR,FLANGED,L=12.1
92075	92075-277	4	DAMPER RUBBER
114	115G0816	2	BOLT-SMALL-UPSET,8X16
114A	115C0816	2	BOLT-SMALL,8X16,BLACK
120	120S0616	4	BOLT-SOCKET,6X16,BLAC
410	410B0800	2	WASHER PLAIN 8MM
410A	92022-1554	2	WASHER,PLAIN,8MM
461	461F0800	2	WASHER SPRING 8MM
461A	461K0800	2	WASHER-SPRING,8MM,BLA
670	670D2014	4	O RING,14MM

E1710-0037

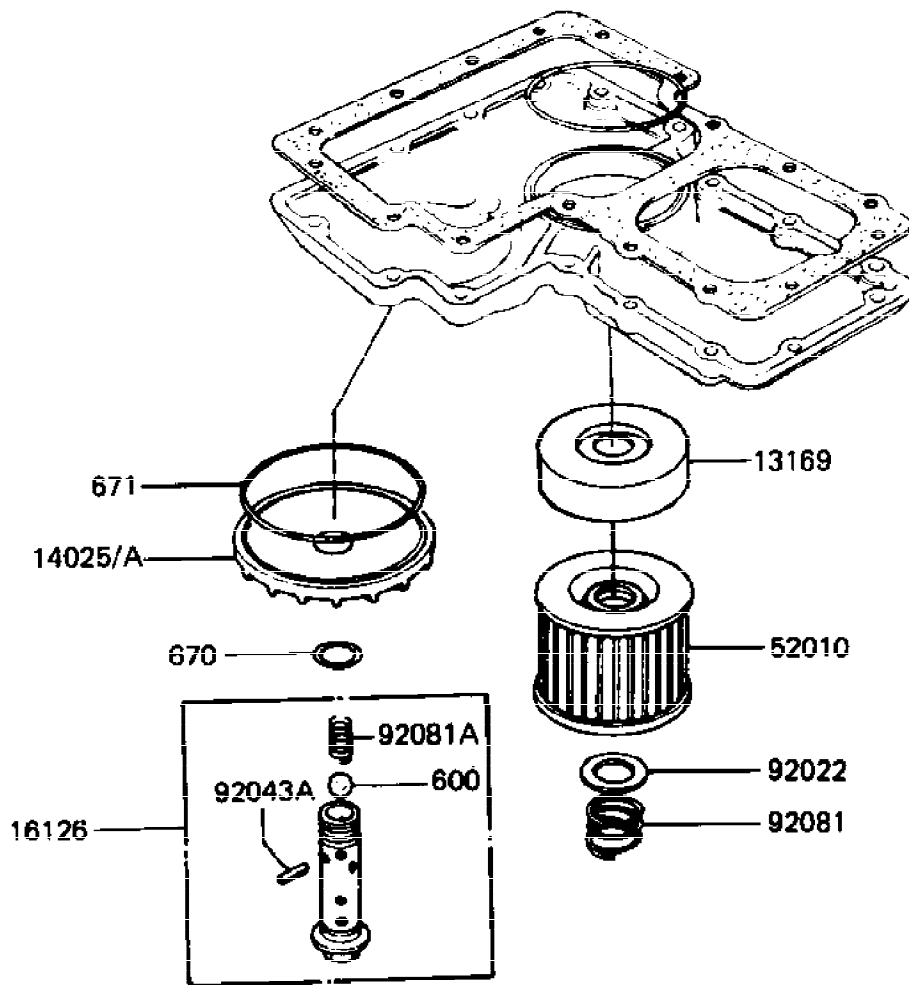
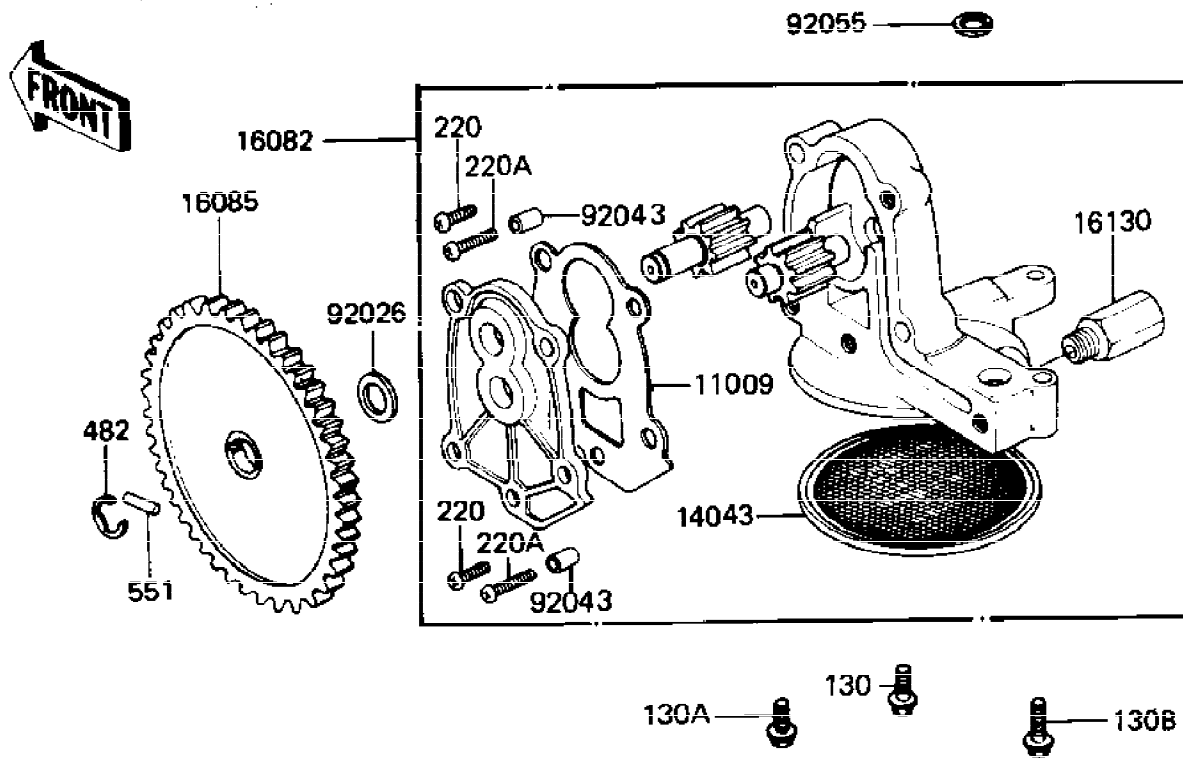

Ref #	Part Number	Qty	Description
11009	11009-1029	1	GASKET,OIL PUMP
13169	13169-1313	1	PLATE,OIL FILTER
14025	14025-1422	1	COVER,OIL FILTER,F.BL
14025A	16101-004	1	COVER,OIL FILTER
14043	16111-004	1	STRAINER,OIL PUMP
16082	16082-5002	1	PUMP-ASSY-OIL
16085	16085-019	1	GEAR,OIL PUMP 49T
16126	16126-1108	1	VALVE,OIL FILTER
16130	16130-1001	1	RELEAF VALVE ASSY
52010	16099-003	1	FILTER,OIL
92022	92022-1012	1	WASHER,20.5X30X1.0
92026	92026-080	1	WASHER,LOCK,16MM
92043	92043-1302	2	PIN,DOWEL,8X10
92043A	92043-111	1	SPRING PIN
92055	92055-048	1	O RING,0.D=18MM
92081	92081-1018	1	SPRING,OIL FILTER
92081A	92081-109	1	SPRING
130	130G0625	1	BOLT,FLANGED,6X25
130A	130H0635	1	BOLT,FLANGED,6X35
130B	130G0645	1	BOLT,FLANGED,6X45
220	220B0618	4	SCREW PAN HEAD 6X18
220A	220B0628	2	SCREW PAN HEAD 6X28
482	482K7000	1	CIRCLIP,7MM
551	551A0314	1	PIN,DOWEL,3X14
600	600A1200	1	BALL STEEL 3/8'
670	670B2016	1	"O" RING,16MM
671	671B2590	1	"O" RING,90MM

F2810-0068

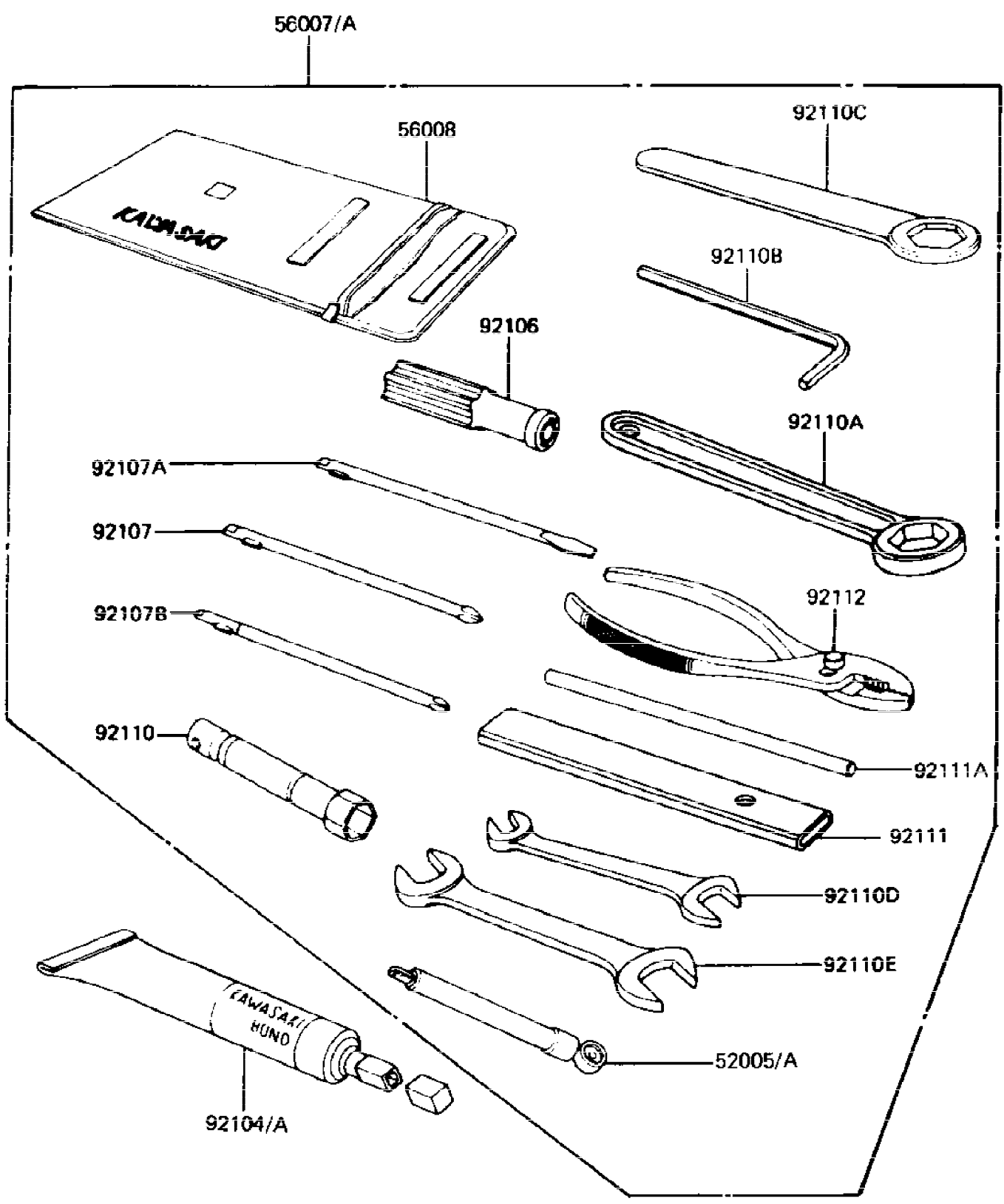

Ref #	Part Number	Qty	Description
52005	52005-1031	1	GAUGE,AIR,3.5KG/CM2
52005A	52005-4002	1	GAUGE,AIR
56007	56007-1121	1	TOOLKIT
56007A	56007-1139	1	56007-1121 (Canada)
56008	56008-006	1	BAG,TOOL
92104	92104-002	1	LIQUID GASKET
92104A	92104-1003	1	GASKET-LIQUID,BLACK
92106	92106-1001	1	GRIP,SCREW DRIVER
92107	92107-1052	1	TOOL-DRIVER
92107A	92107-007	1	92107-1052 (Canada)
92107B	92107-008	1	92107-1002 (Canada)
92110	92108-008	1	WRENCH,SPARK PLUG
92110A	92110-1147	1	TOOL-WRENCH,BOX END,2
92110B	92110-1015	1	WRENCH,ALLEN
92110C	92110-1148	1	TOOL-WRENCH,BOX END,2
92110D	92110-1038	1	TOOL-WRENCH,OPEN END
92110E	92110-1153	1	TOOL-WRENCH,OPEN END,
92111	92111-004	1	TOOL-WRENCH,OPEN END,
92111A	92111-005	1	BAR,SPARK PLUG WRENCH
92112	92112-003	1	PLIERS,160MM

F2294-0006

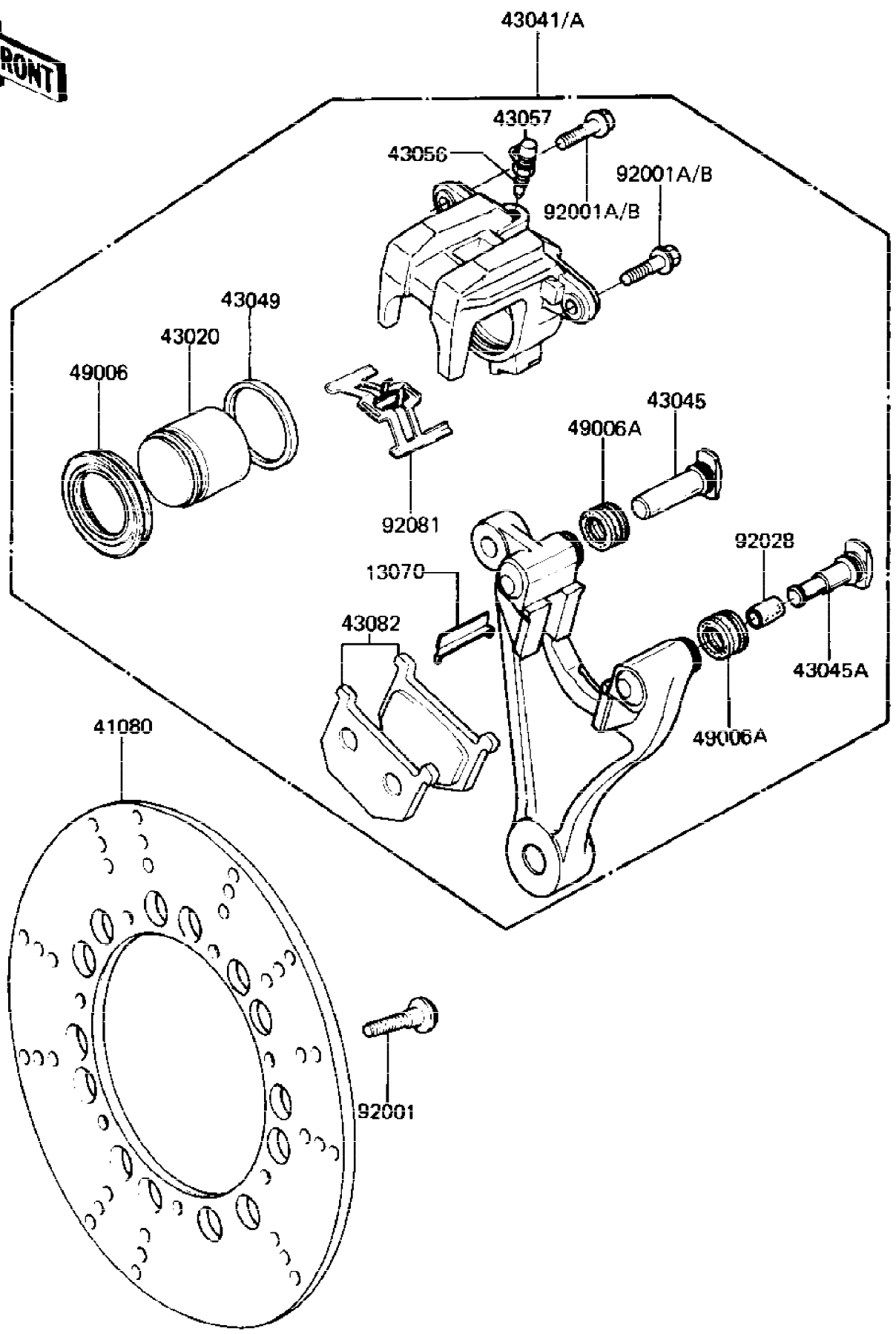

Ref #	Part Number	Qty	Description
13070	13070-1026	2	GUIDE,PAD
41080	41080-1128	1	DISC,RR,SILVER
43020	43020-1096	1	PISTON-COMP-BRAKE
43041	43041-1047	1	CALIPER-ASSY,RR
43041A	43041-1061	1	CALIPER-ASSY,REAR
43045	43045-1007	1	SHAFT,CALIPER
43045A	43045-1008	1	SHAFT,CALIPER
43049	43049-002	1	RING,PISTON SEAL
43056	43056-003	1	BREEDER
43057	43057-003	1	CAP,BREEDER
43082	43082-1022	1	PAD-ASSY,RR
49006	49006-1043	1	DUST SEAL,PISTON
49006A	49006-1044	2	DUST SEAL
92001	92001-1951	7	BOLT,SOCKET,8X30
92001A	92001-1510	2	BOLT,FLANGED,8X25,BLA
92001B	92001-1510	2	BOLT,FLANGED,8X25,BLA
92028	92028-1090	1	BUSHING,SHAFT CALIPER
92081	92081-1229	1	SPRING,PAD



F2293-0020

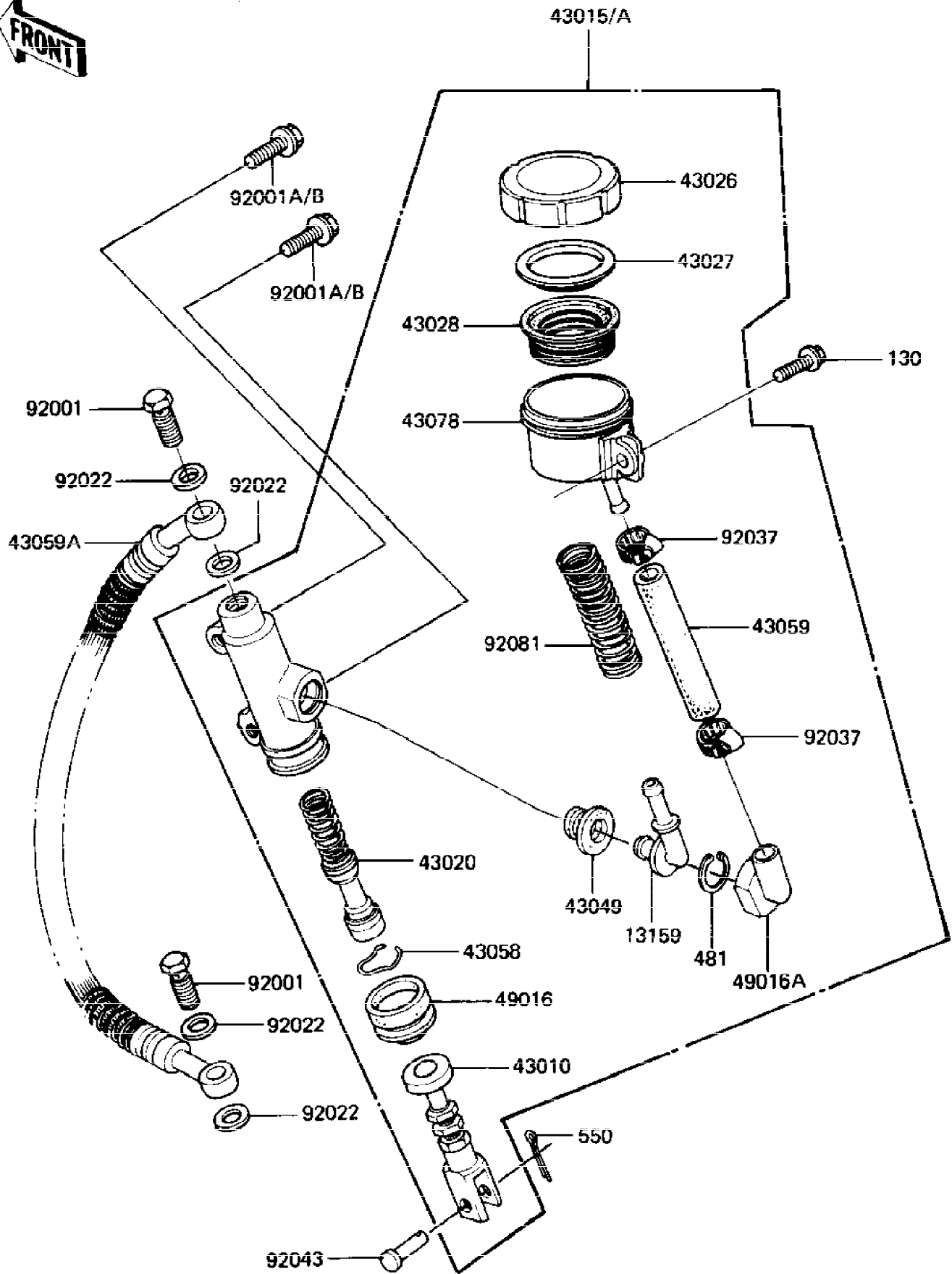

Ref #	Part Number	Qty	Description
13159	13159-1009	1	CONNECTOR
43010	43010-1004	1	ROD ASSY,BRAKE
43015	43015-1134	1	CYLINDER-ASSY-MASTER
43015A	43015-1091	1	CYLINDER-ASSY-MASTER
43020	43020-1019	1	PISTON ASSY
43026	43026-1016	1	CAP-BRAKE
43027	43027-1005	1	PLATE,DIAPHRAGM
43028	43028-1016	1	DIAPHRAGM
43049	43049-1008	1	PACKING
43058	43058-004	1	RING,DUST SEAL
43059	43059-1096	1	HOSE-BRAKE
43059A	43059-1186	1	HOSE-BRAKE,L=415
43078	43078-1009	1	RESERVOIR
49016	49016-1031	1	DUST COVER
49016A	49016-1034	1	COVER-SEAL
92001	92002-1888	2	BOLT,OIL,L=23
92001A	92001-1095	2	BOLT,8X28
92001B	92001-1508	2	BOLT,FLANGED,8X28,BLA
92022	43067-001	4	WASHER-OIL BOLT
92037	92037-1154	2	CLAMP,BRAKE HOSE
92043	92043-1013	1	PIN
92081	92081	1	UNAVAILABLE IN PRICE BOOK
130	130B0620	1	BOLT,FLANGED,6X20
481	481J2500	1	CIRCRIP-TYPE-C
550	550D2015	1	PIN COTTER 2.0X15

F2240-0068

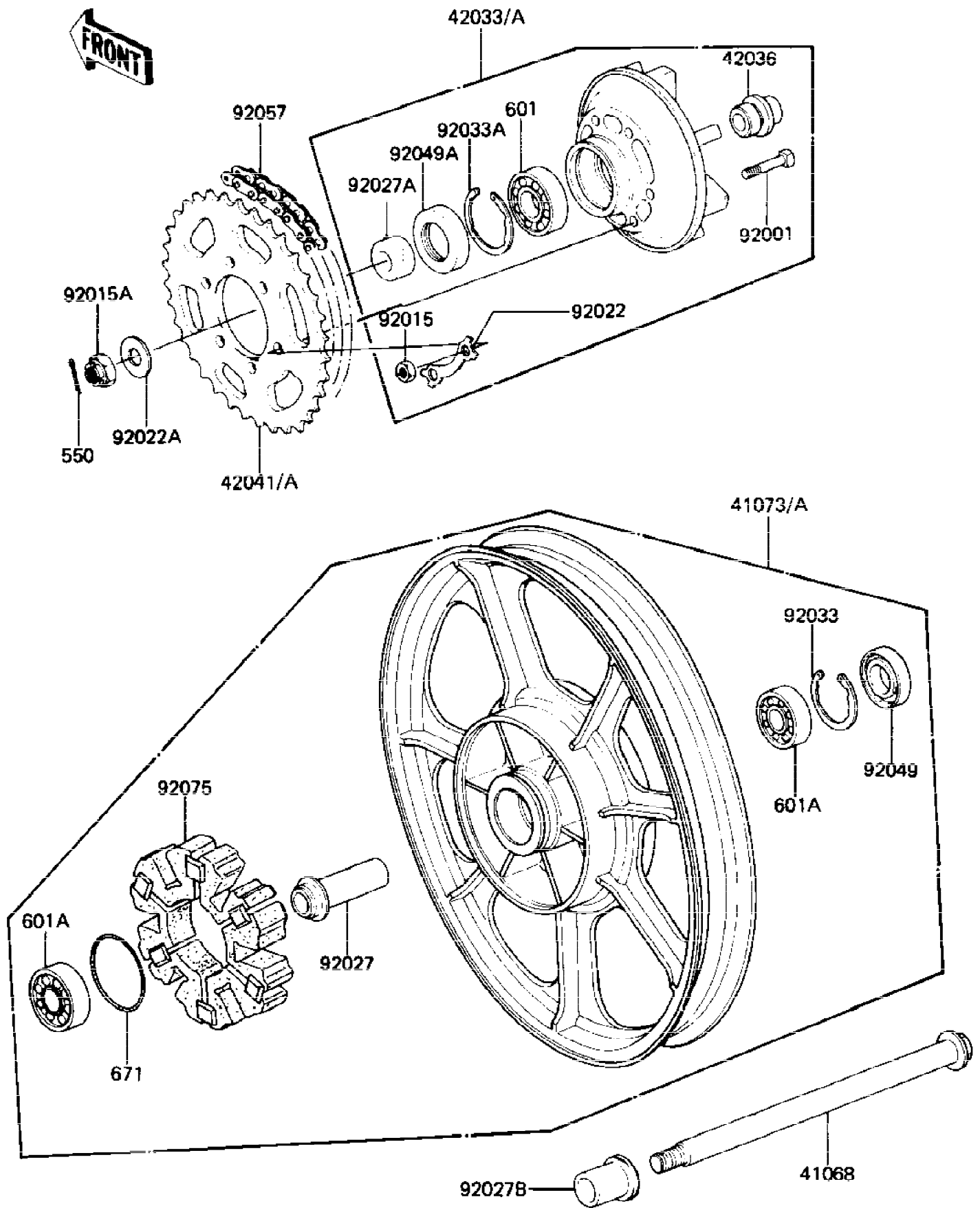

Ref #	Part Number	Qty	Description
41068	41068-1087	1	AXLE,RR,L=300
41073	41073-1141-21	1	WHEEL-ASSY,RR,SOLID,B
41073A	41073-1141-21	1	WHEEL-ASSY,RR,SOLID,B
42033	42033-1024	1	COUPLING-ASSY
42033A	42033-1048	1	COUPLING-ASSY,F.BLACK
42036	42036-1039	1	SLEEVE,L=33
42041	42041-1058	1	SPROCKET-HUB,41T
42041A	42041-1106	1	SPROCKET-HUB,42T,BLAC
92001	92001-161	6	BOLT
92015	42045-005	6	NUT 10MM
92015A	42045-018	1	NUT CASTLE,18MM
92022	92022-1212	3	WASHER,LOCK
92022A	92022-248	1	WASHER,PLAIN,20MM
92027	92027-1286	1	COLLAR,L=89.5
92027A	92027-1287	1	COLLAR,20X40X18
92027B	92027-1288	1	COLLAR,L=31
92033	92033-1043	1	RING,SNAP,56.2M/M
92033A	92033-1044	1	CIRCLIP,62M/M
92049	92049-1061	1	SEAL-OIL
92049A	92050-027	1	OIL SEAL
92057	92057-1152	1	DR CHAIN EK630 98L
92075	42014-033	1	SHOCK DAMPER,REAR HUB
550	550D4035	1	PIN-COTTER,4.0X35
601	601B6206	1	BALL BEARING,#6206
601A	601B6304ZZ	2	BEARING,BALL,#6304ZZ
671	671B2565	1	"0" RING,65MM

F2510-0112

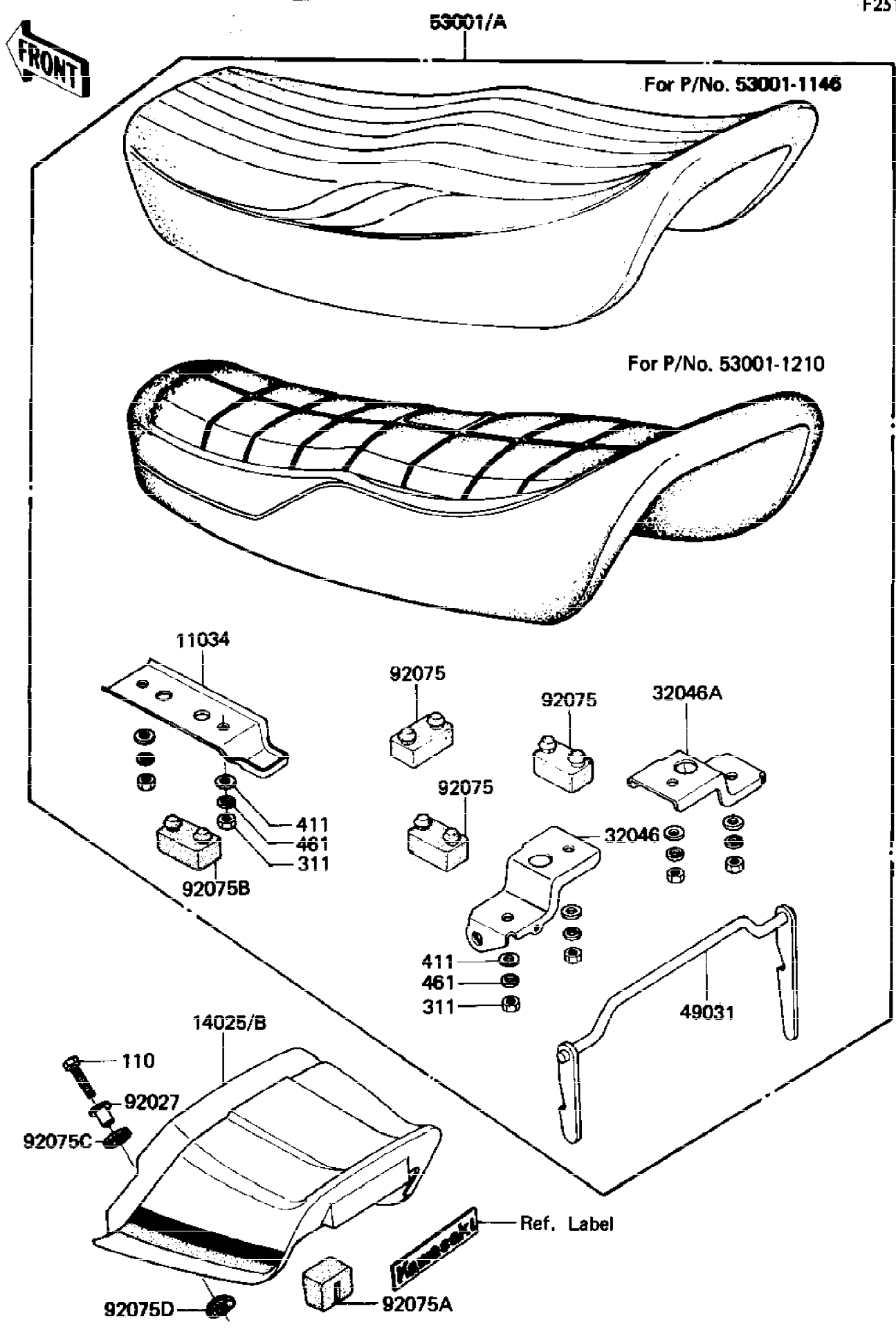

Ref #	Part Number	Qty	Description
11034	11034-1868	2	BRACKET,SEAT,FR
14025	14025-1267-B1	1	COVER,SEAT,F.RED
14052B	14025-5055-B1	1	COVER,SEAT,F.RED
32046	32046-1089	1	BRACKET-SEAT,LH
32046A	32046-1090	1	BRACKET-SEAT,RH
49031	49031-1006	1	LATCH,SEAT
53001	53001-1206	1	SEAT,ASSY
53001A	53001-1210	1	SEAT-ASSY
92027	92027-251	2	COLLAR
92075	92075-1276	3	DAMPER,SEAT,RR
92075A	92075-1313	1	DAMPER,SEAT
92075B	92075-139	2	DAMPER RUBBER,SEAT
92075C	92075-174	2	RUBBER,FENDER COVER
92075D	92075-175	2	DAMPER RUBBER
110	112G0620	2	BOLT-UPSET,6X20
311	311B0600	8	NUT 6MM
411	411B0600	8	WASHER PLAIN 6MM
461	461F0600	8	WASHER SPRING 6MM

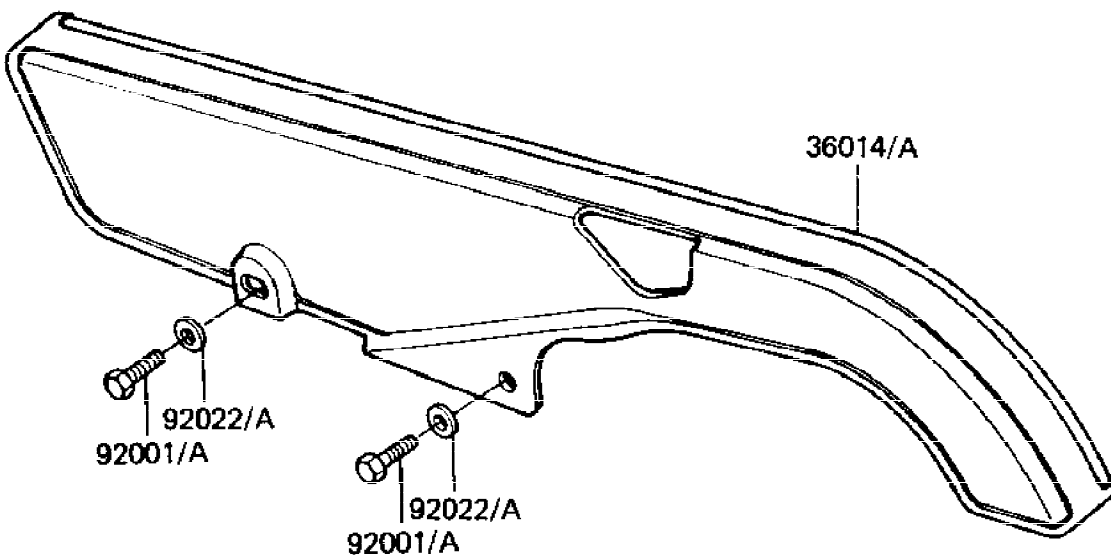
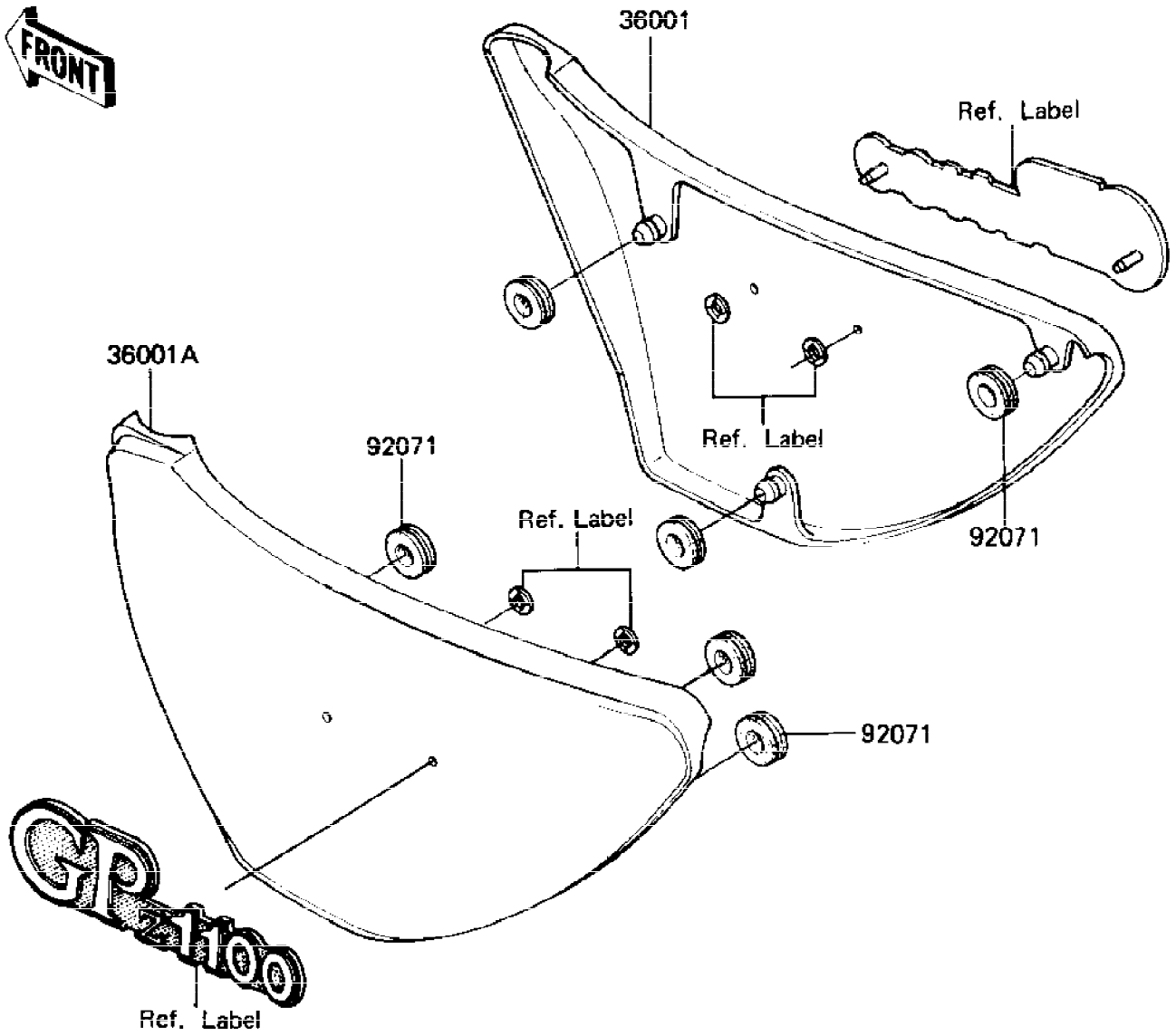

Ref #	Part Number	Qty	Description
36001	36001-1108-B1	1	COVER-SIDE,RH,F.RED
36001A	36001-1109-B1	1	COVER-SIDE,LH,F.RED
36014	36014-1061	1	CASE-CHAIN
36014A	36014-1061	1	CASE-CHAIN
92001	92001-115	2	BOLT,HEAX HEAD,6X14
92001A	92001-1658	2	BOLT,6X14,BLACK
92022	92022-1317	2	WASHER,8.5X20X1.6,BLA
92022A	92022-1561	2	WASHER,8.5X20X1.6
92071	92071-056	6	GROMMET



F2190-0074

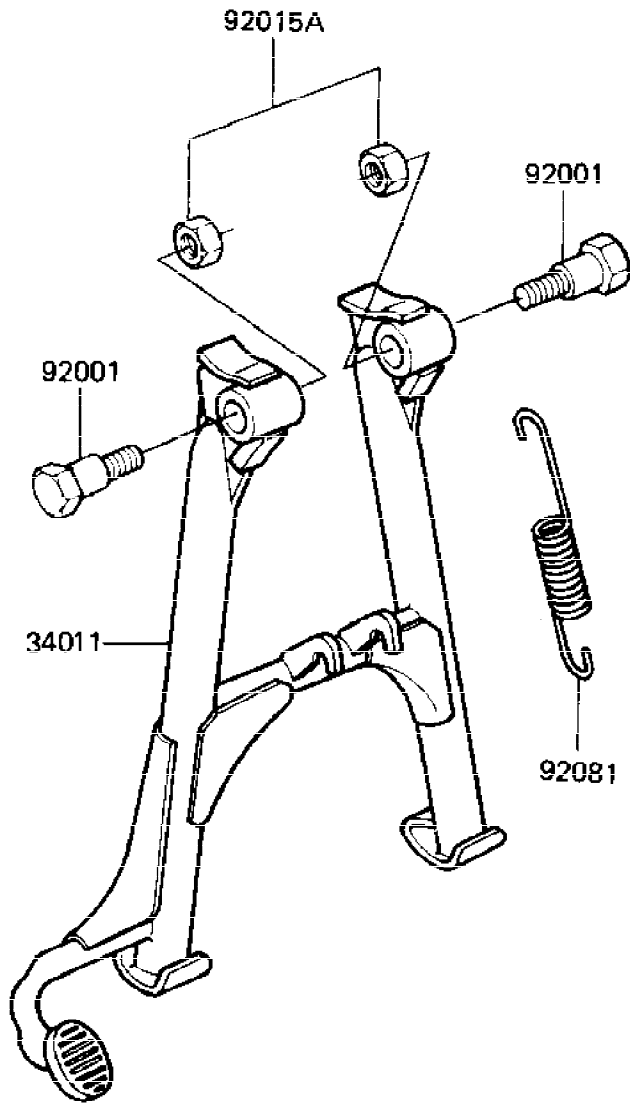
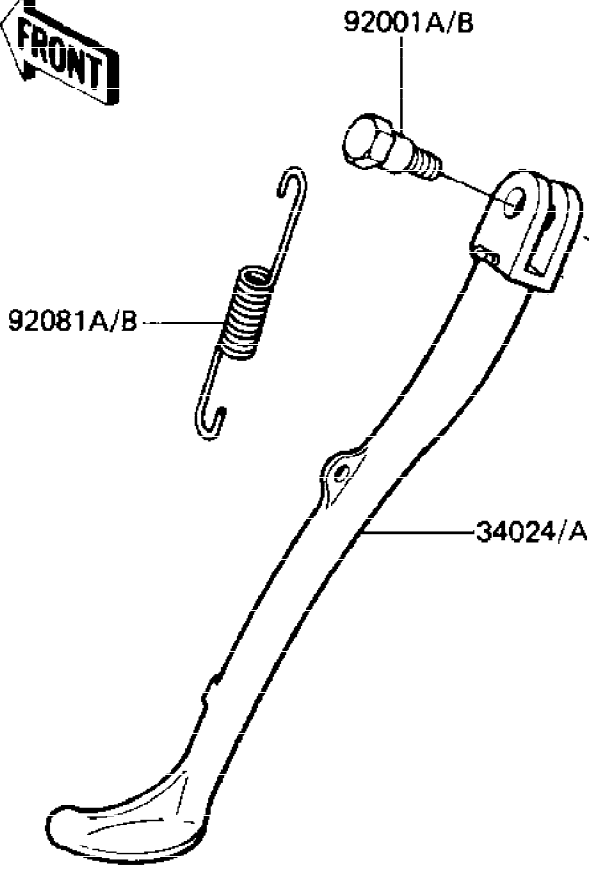

Ref #	Part Number	Qty	Description
34011	34011-1032	1	STAND-MAIN
34024	34024-1070	1	STAND-SIDE
34024A	34024-1097	1	STAND-SIDE
92001	92001-1214	1	BOLT,MAIN STAND FITTI
92001A	92001-1543	1	BOLT,8X160,BLACK
92001B	92003-079	1	BOLT-SIDE STAND
92015	92015-1188	1	NUT,LOCK,10MM,BLACK
92015A	92019-021	3	NUT,LOCK,10MM
92015A	92019-021	2	NUT,LOCK,10MM
92081	34023-012	1	SPRING,MAIN STAND
92081A	34025-005	1	SPRING,SIDE STAND
92081B	92081-1727	1	SPRING,SIDE STAND

E1840-0010

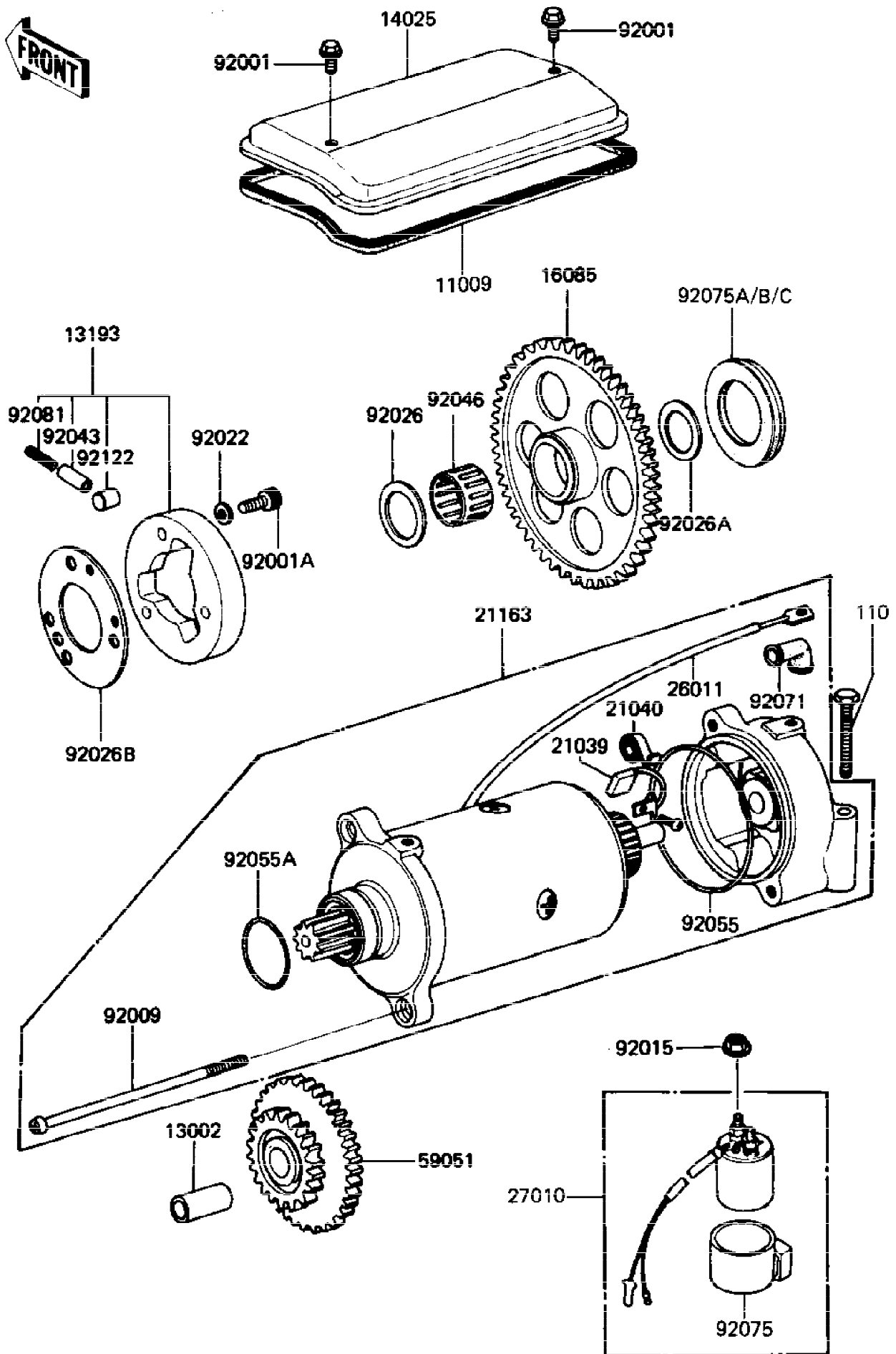

## STARTER MOTOR/STARTER CLUTCH (KZ1100-B1)

Ref #	Part Number	Qty	Description
11009	21166-001	1	GASKET,START MOTOR CV
13002	13002-007	1	PIN-PISTON
13193	13193-1006	1	CLUTCH ASSY,STARTING
14025	14025-1378	1	COVER,STARTER,BLACK
16085	16085-1012	1	GEAR,STARTING CLUTCH
21039	21039-003	2	CARBON BRUSH
21040	21040-003	2	SPRING,CARBON BRUSH
21163	21163-1019	1	STARTER-ELECTRIC
26011	26010-055	1	WIRE,STARTER MOTOR
27010	21164-005	1	SWITCH ASSY,MAGNETIC
59051	21167-002	1	GEAR,STARTING MOTOR
92001	92001-1151	2	BOLT,6X10
92001A	120P0816	3	BOLT
92009	21015-005	2	SCREW,PAN HEAD,6X110
92015	92015-1073	2	NUT,SGNL LAMP BRACKET
92022	92022-1108	3	WASHER,PLAIN
92026	92026-1031	1	SPACER
92026A	92026-1033	1	SPACER
92026B	92026-112	1	PLATE,CLUTCH STARTER
92043	92043-087	3	PIN
92046	92046-1022	1	BEARING,NEEDLE,K25302
92055	21027-003	1	"0" RING,STARTING MTR
92055A	21027-004	1	"0" RING,STARTING MTR
92071	21017-017	2	GROMMET,CORD
92075	21064-002	1	DAMPER MAG SWITCH SHK
92075A	92075-1129	AR	DAMPER RUBBER,6.3T
92075B	92075-1130	AR	DAMPER RUBBER,7.3T
92075C	92075-1131	AR	DAMPER RUBBER,8.3T
92081	92081-110	3	SPRING
92122	92122-001	3	PIN
110	92001-1456	2	BOLT,EXCLUSIVE

E1840-0024

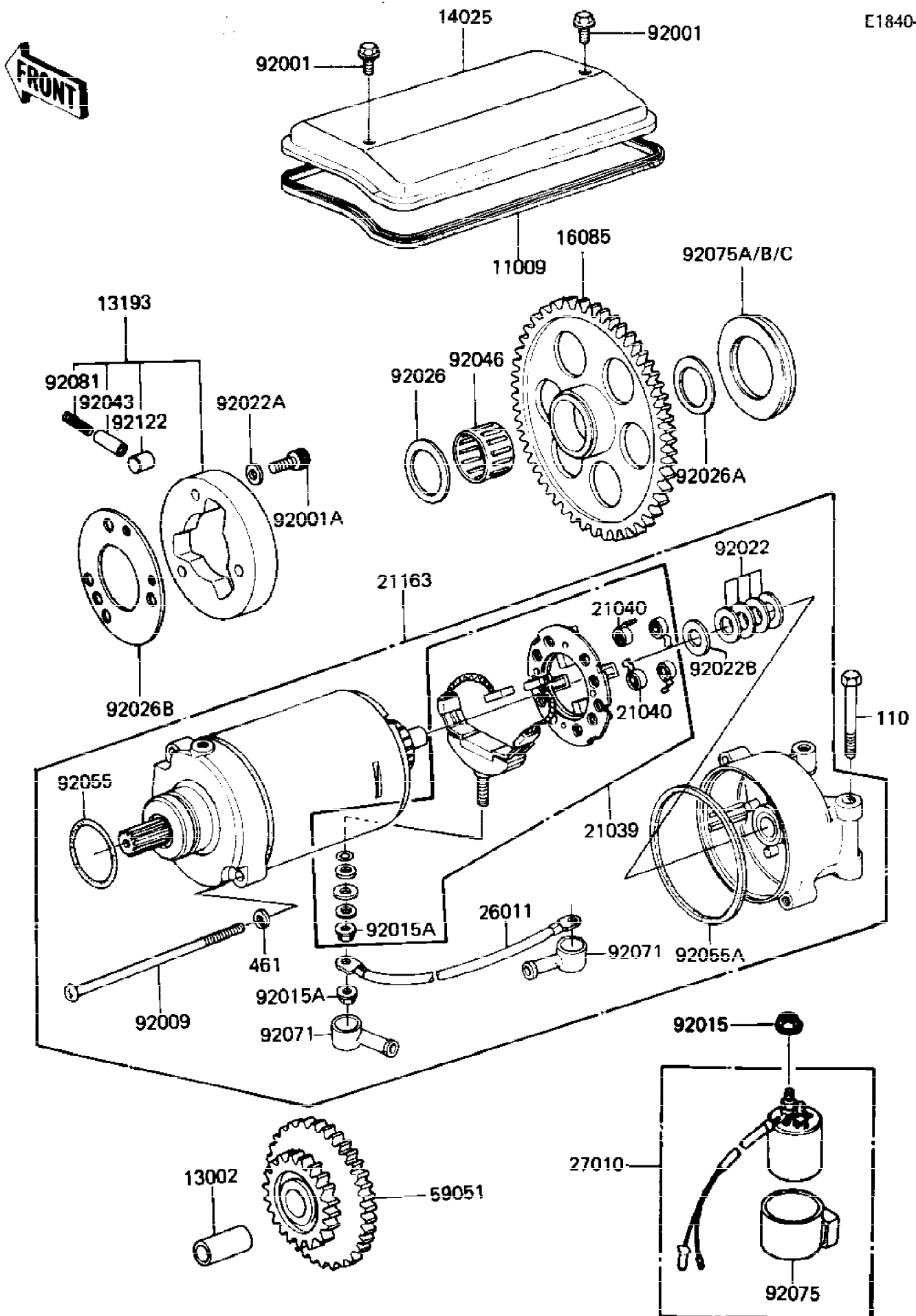

## STARTER MOTOR/STARTER CLUTCH (KZ1100-B2)

Ref #	Part Number	Qty	Description
11009	21166-001	1	GASKET,START MOTOR CV
13002	13002-007	1	PIN-PISTON
13193	13193-1006	1	CLUTCH ASSY,STARTING
14025	14025-1378	1	COVER,STARTER,BLACK
16085	16085-1012	1	GEAR,STARTING CLUTCH
21039	21039-1005	1	BRUSH SET,CARBON
21040	21040-1002	4	SPRING,CARBON BRUSH
21163	21163-1019	1	STARTER-ELECTRIC
26011	26011-1073	1	WIRE,STARTER MOTOR
27010	21164-005	1	SWITCH ASSY,MAGNETIC
59051	21167-002	1	GEAR,STARTING MOTOR
92001	92001-1525	2	BOLT,6X10,BLACK
92001A	120P0816	3	BOLT
92009	21015-005	2	SCREW,PAN HEAD,6X110
92015	92015-1078	2	NUT-6MM
92015A	92015-1078	2	NUT-6MM
92022	21025-011	4	WASHER,THRUST,0.2T
92022A	92022-1108	3	WASHER,PLAIN
92022B	92022-1132	1	WASHER,THRUST,0.8T
92026	92026-1031	1	SPACER
92026A	92026-1033	1	SPACER
92026B	92026-112	1	PLATE,CLUTCH STARTER
92043	92043-087	3	PIN
92046	92046-1022	1	BEARING,NEEDLE,K25302
92055	21027-004	1	"O" RING,STARTING MTR
92055A	92055-1086	2	"O" RING,STARTER MOTR
92071	21017-017	2	GROMMET,CORD
92075	21064-002	1	DAMPER MAG SWITCH SHK
92075A	92075-1129	1	DAMPER RUBBER,6.3T
92075B	92075-1130	1	DAMPER RUBBER,7.3T
92075C	92075-1131	1	DAMPER RUBBER,8.3T
92081	92081-110	3	SPRING
92122	92122-001	3	PIN
110	92001-1456	2	BOLT,EXCLUSIVE
461	461F0500	2	WASHER SPRING 5MM

F2140-0113

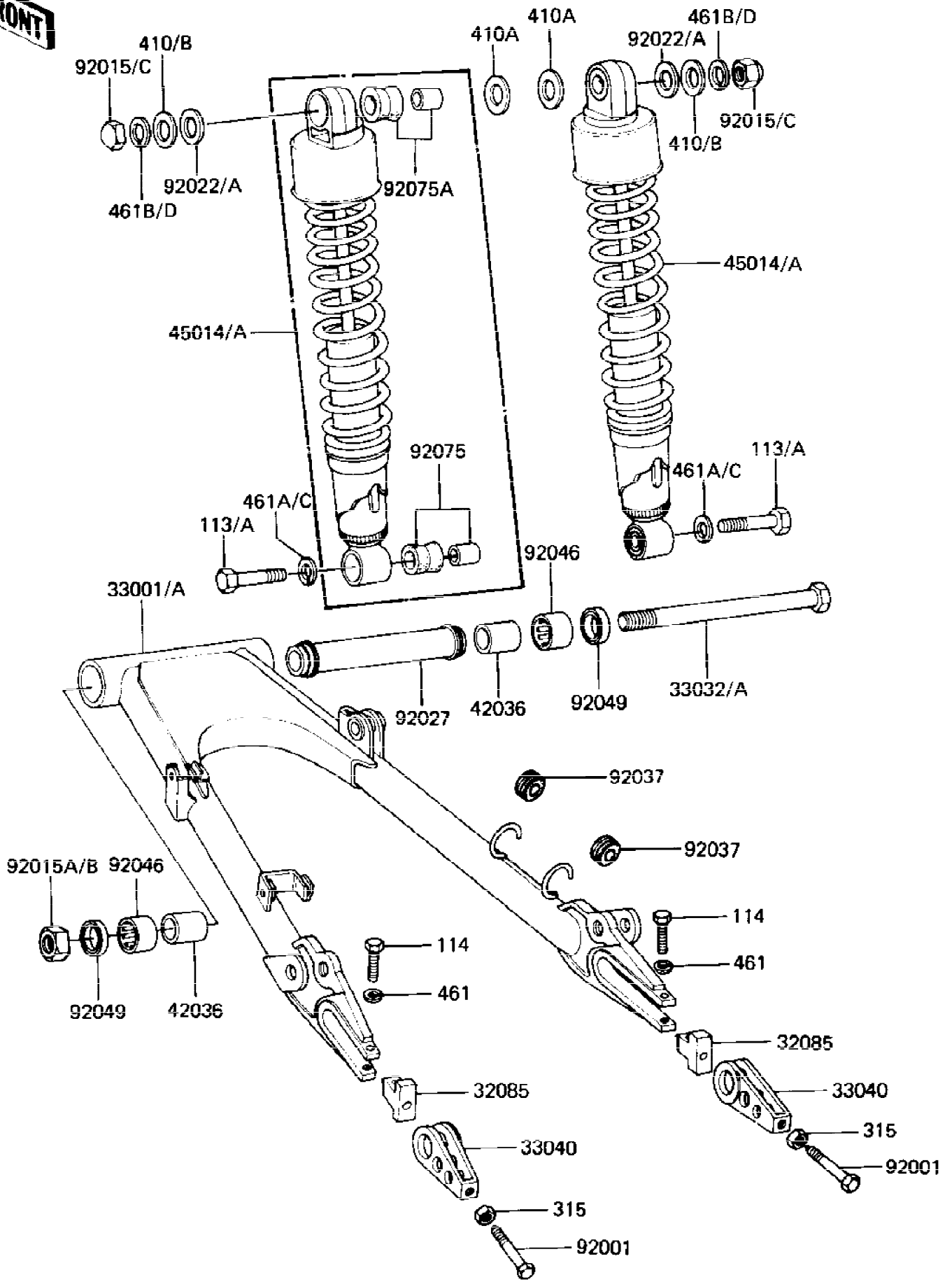

Ref #	Part Number	Qty	Description
32085	33044-001	2	STOPPER,CHAIN ADJUST
33001	33001-1217	1	ARM-COMP-SWING,BLACK
33001A	33001-1217	1	ARM-COMP-SWING,BLACK
33032	33032-036	1	SHAFT,SWING ARM PIVOT
33032A	33032-1027	1	SHAFT-SWING ARM,BLACK
33040	33040-066	2	ADJUSTER,CHAIN
42036	42036-1040	2	SLEEVE,SWING ARM
45014	45014-1135	2	SHOCK ABSBR RR
45014A	45014-1170-10	2	SHOCKABSORBER,RR,BLAC
92001	92001-143	2	BOLT-CHN ADJUST 10MM
92015	92015-1192	2	NUT,LOCK,CAP,12MM,BLA
92015A	92015-1207	1	NUT,LOCK,16MM,BLACK
92015B	92019-012	1	NUT-SELF LOCKING
92015C	92020-014	2	NUT 12MM
92022	92022-1239	2	WASHER,12.4X28X2.3
92022A	92022-1303	2	WASHER,12.4X28X2.3,BL
92027	92027-1301	1	COLLAR,SWING ARM,L=15
92037	43064-007	2	DAMPER RUBBER
92046	92046-1035	2	BEARING-NEEDLE
92049	92049-1060	2	SEAL-OIL
92075	45017-019	2	BUSHING,SHOCK ABSORBE
92075A	92075-1141	2	BUSHING,SHOCK ABSORBE
1113	112C1035	2	BOLT-SMALL-FINE,10X35
1113A	113N1035	2	BOLT HEX HEAD 10X35
1114	115G0840	2	BOLT,8X40
315	315B1000	2	NUT 10MM
410	410B1200	2	WASHER PLAIN 12MM
410A	410B1400	2	WASHER PLAIN 14MM
410B	410F1200	2	WASHER-PLANE-SMALL
461	461F0800	2	WASHER SPRING 8MM
461A	461F1000	2	WASHER SPRING 10MM
461B	461F1200	2	WASHER SPRING 12MM
461C	461K1000	2	WASHER-SPRING,10MM
461D	461K1200	2	WASHER-SPRING,12MM,BL



F2720-0094

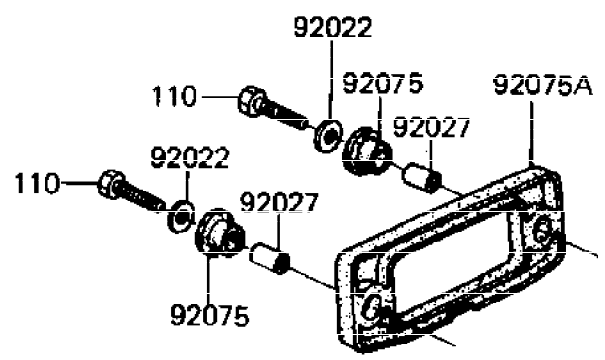
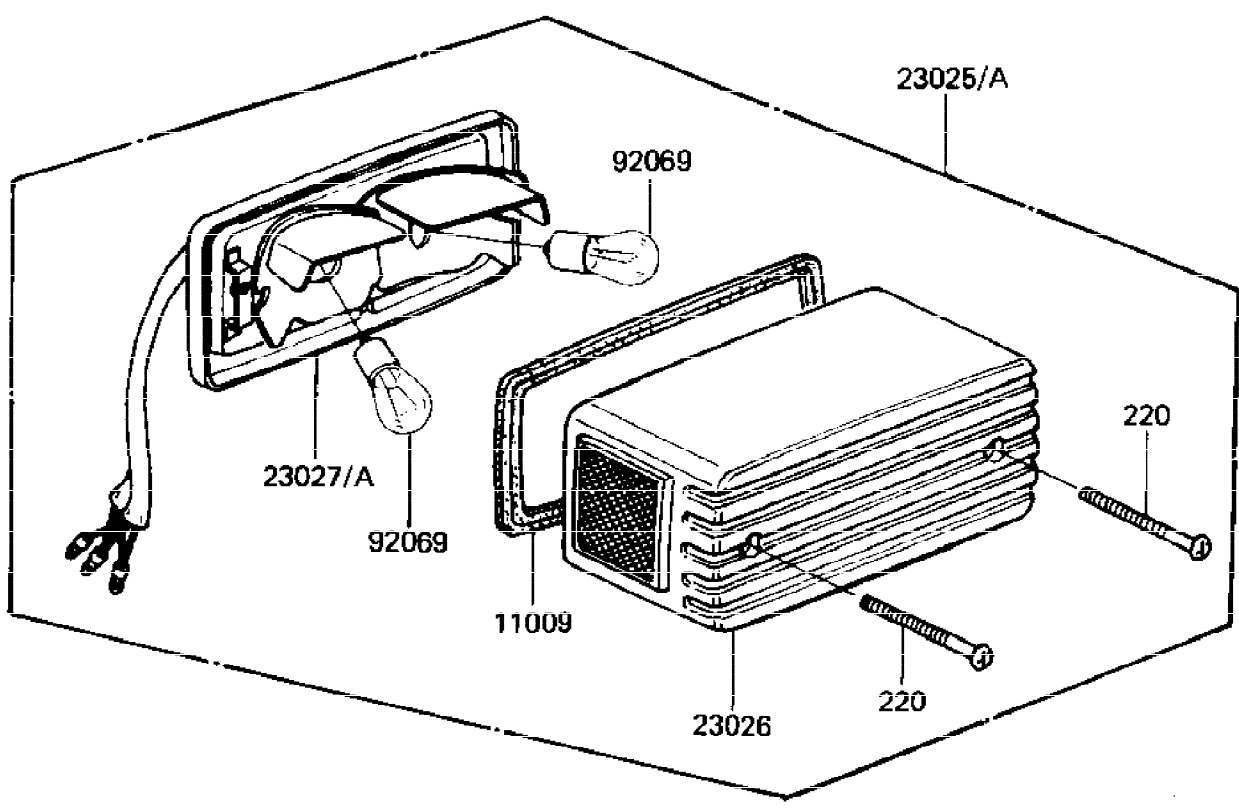

Ref #	Part Number	Qty	Description
11009	11009-1221	1	GASKET, TAIL LAMP
23025	23025-1025	1	LAMP-TAIL
23025A	23025-1038	1	LAMP-TAIL, BLACK
23026	23026-1021	1	LENS, TAIL LAMP
23027	23027-1013	1	BODY-COMP-TAIL LAMP
23027A	23027-1025	1	BODY-COMP-TAIL LAMP, B
92022	92022-125	2	WASHER 6.5X20X1.6T
92027	92027-1316	2	COLLAR, 6.8X10X17.6
92069	92069-059	2	BULB, 12V 32/3CP
92075	92075-1092	2	DAMPER RUBBER
92075A	92075-1282	1	DAMPER
110	112G0625	2	BOLT-UPSET
220	220C0465	2	SCREW-PAN-CROS

E1510-0003

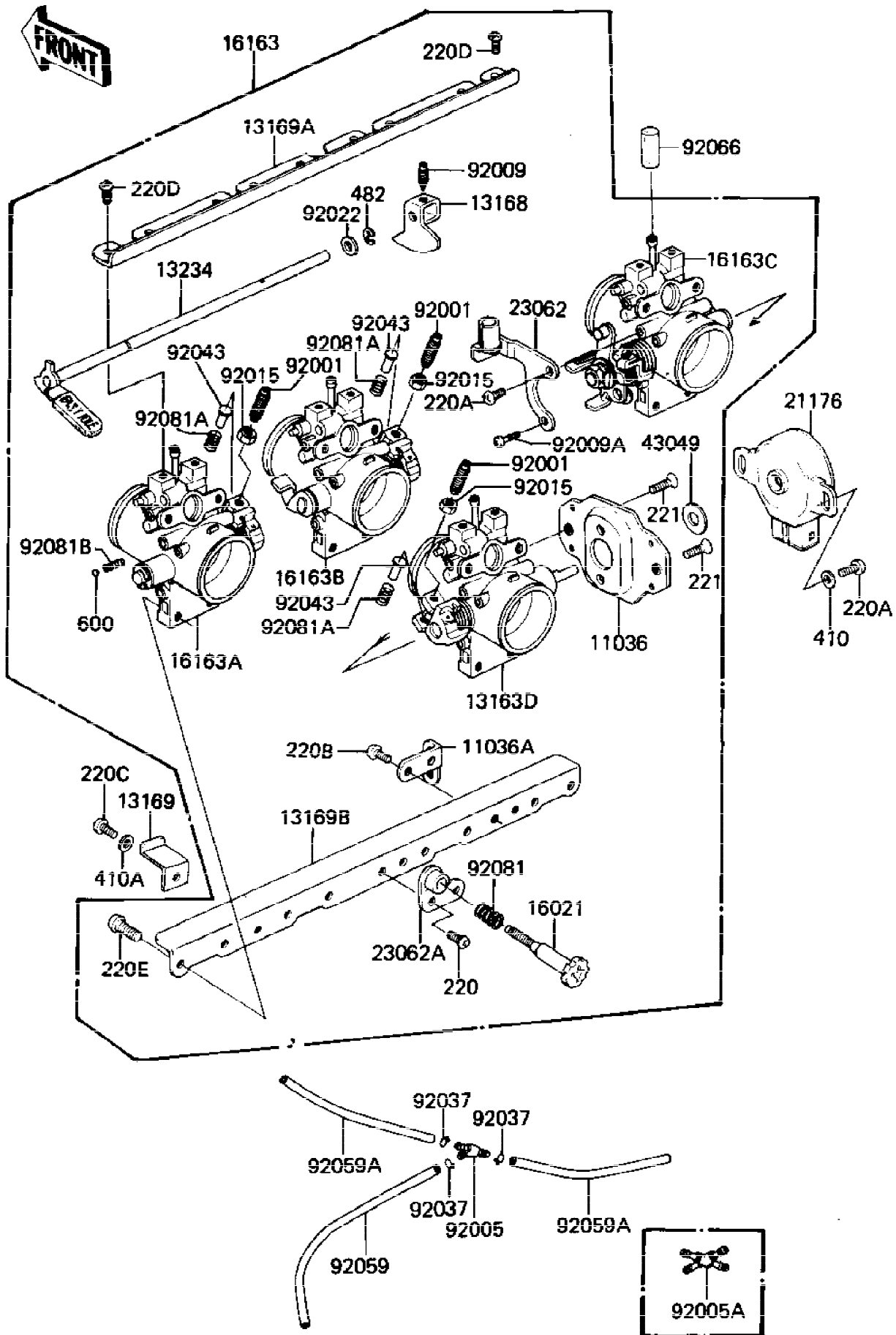

Ref #	Part Number	Qty	Description
11036	11036-1481	1	BRACKET-A,THROTTLE SE
11036A	11036-1491	1	BRACKET-A,STAY LWR
13168	13168-1118	1	LEVER,FAST IDLE
13169	13169-1441	1	PLATE,PROTECTOR
13169A	13169-1521	1	PLATE,THROTTLE STAY,U
13169B	13169-1522	1	PLATE,THROTTLE STAY,L
13234	13234-1008	1	SHAFT-COMP,FAST IDLE
16021	16021-1010	1	SCREW,THROTTLE STOP
16163	16163-1013	1	THROTTLE-ASSY
16163A	16163-1016	1	THROTTLE-ASSY,LH,OUTS
16163B	16163-1017	1	THROTTLE-ASSY,LH,INSI
16163C	16163-1018	1	THROTTLE-ASSY,RH,INSI
16163D	16163-1019	1	THROTTLE-ASSY,RH,OUTS
21176	21176-1004	1	SENSOR,THROTTLE
23062	23062-1026	1	BRACKET-COMP,TH CABLE
23062A	23062-1027	1	BRACKET,IDLING ADJUST
43049	43049-1021	1	PACKING,THROTTLE SENS
92001	92001-1447	3	BOLT,ADJUSTING
92005	92005-1017	1	FITTING,TUBE CN
92005A	92005-1051	1	FITTING,FUEL,X-TYPE US
92009	92009-1147	1	SCREW,FAST IDLE LEVER
92009A	92009-1148	1	SCREW,THROTTLE CABLE
92015	92015-1119	3	NUT,THROTTLE VLV ADST
92022	16039-019	1	WASHER,PLAIN
92037	92037-072	3	CLAMP-PIPE
92043	92043-1079	3	PIN,THROTTLE VALVE
92059	92059-1043	1	TUBE,4X9X290
92059A	92059-1162	2	TUBE,VACUUM,LONG
92066	92068-006	2	RUBBER PLUG
92081	16022-017	1	SPRING,THROTTLE STOP
92081A	92081-1259	3	SPRING,THROTTLE VALVE
92081B	92081-1260	1	SPRING,FAST IDLE SHFT
220	220B0506A	1	SCREW PAN HEAD 5X6
220A	220B0510	3	SCREW PAN HEAD 5X10
220B	220C0506	2	SCREW-PAN-CROSS
220C	220C0508	1	SCREW-PAN-CROS
220D	220C0510	8	SCREW-PAN-CROS
220E	220C061	8	UNAVAILABLE IN PRICE BOOK
221	221B0510A	2	SCREW CNTSNK HD 5X10
410	410B0500	2	WASHER PLAIN 5MM
410A	410F0500	1	WASHER PLAIN
482	482L4000	1	CIRCLIP-TYPE-E
600	600A0400	1	BALL,STEEL,1/8"

E1510-0002

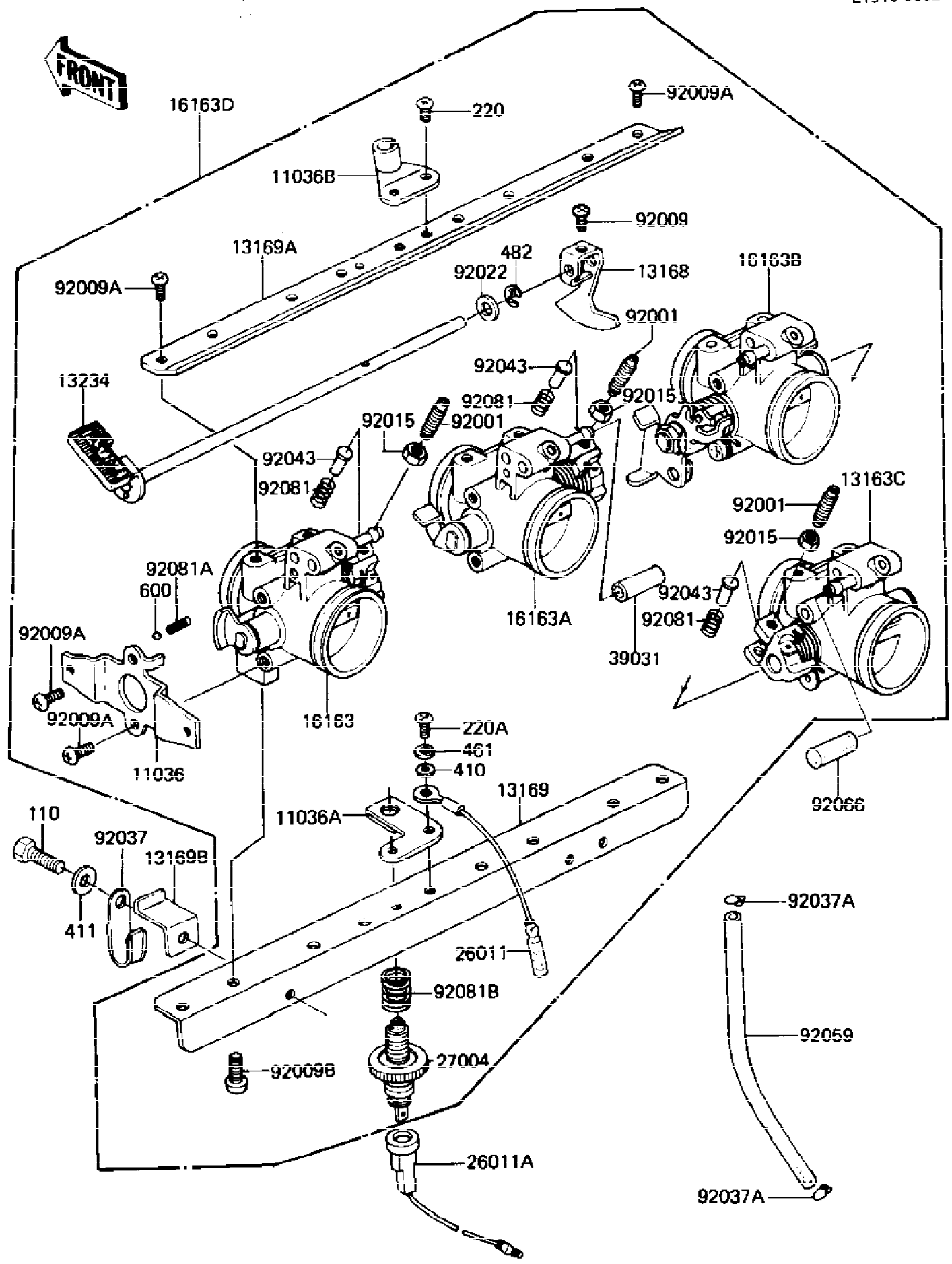

Ref #	Part Number	Qty	Description
11036	11036-1081	1	BRACKET-A,THROTTLE SW
11036A	11036-1082	1	BRACKET-A,IDLE SWITCH
11036B	11036-1211	1	BRACKET-A,THRTTL CABL
13168	13168-1089	1	LEVER,FAST IDLE
13169	13169-1403	1	PLATE,THRTTL STAY,LWR
13169A	13169-1439	1	PLATE,THRTTL STAY,UPP
13169B	13169-1441	1	PLATE,PROTECTOR
13234	13234-1005	1	SHAFT-COMP,FAST IDLE
16163	16163-1007	1	THROTTLE-ASSY,LH,OUT
16163A	16163-1008	1	THROTTLE-ASSY,LH,IN
16163B	16163-1009	1	THROTTLE-ASSY,RH,IN
16163C	16163-1010	1	THROTTLE-ASSY,RH,OUT
16163D	16163-1011	1	THROTTLE-ASSY
26011	26011-1068	1	WIRE,LEAD
26011A	26011-1127	1	WIRE-LEAD,IDLE SWITCH
27004	27004-1010	1	SWITCH-ASSY-IDLING
39031	39031-1009	1	CAP-END
92001	92001-1447	3	BOLT,ADJUSTING
92009	16046-007	1	SCREW,PAN HEAD,5X7
92009A	220B0510	10	SCREW PAN HEAD 5X10
92009B	220B0614	8	SCREW PAN HEAD 6X14
92015	92015-1119	3	NUT,THROTTLE VLV ADST
92022	16039-019	1	WASHER,PLAIN
92037	21126-008	1	CLAMP,WIRING HARNESS
92037A	92037-072	2	CLAMP-PIPE
92043	92043-1079	3	PIN,THROTTLE VALVE
92059	92059-1043	1	TUBE,4X9X290
92066	92068-006	2	RUBBER PLUG CN
92081	92081-1259	3	SPRING,THROTTLE VALVE
92081A	92081-1260	1	SPRING,FAST IDLE SHFT
92081B	92081-1392	1	SPRING,IDLING ADJUST
110	110B0510	1	BOLT HEX HEAD 5X10
220	220B0508	1	SCREW PAN HEAD 5X8
220A	220B0510	1	SCREW PAN HEAD 5X10
410	410B0500	1	WASHER PLAIN 5MM
411	411B0500	1	WASHER PLAIN 5MM
461	461F0500	1	WASHER SPRING 5MM
482	482K4000	1	CIRCLIP SELD BEM FIT
600	600A0400	1	BALL,STEEL,1/8"

F2210-0046

FRONT

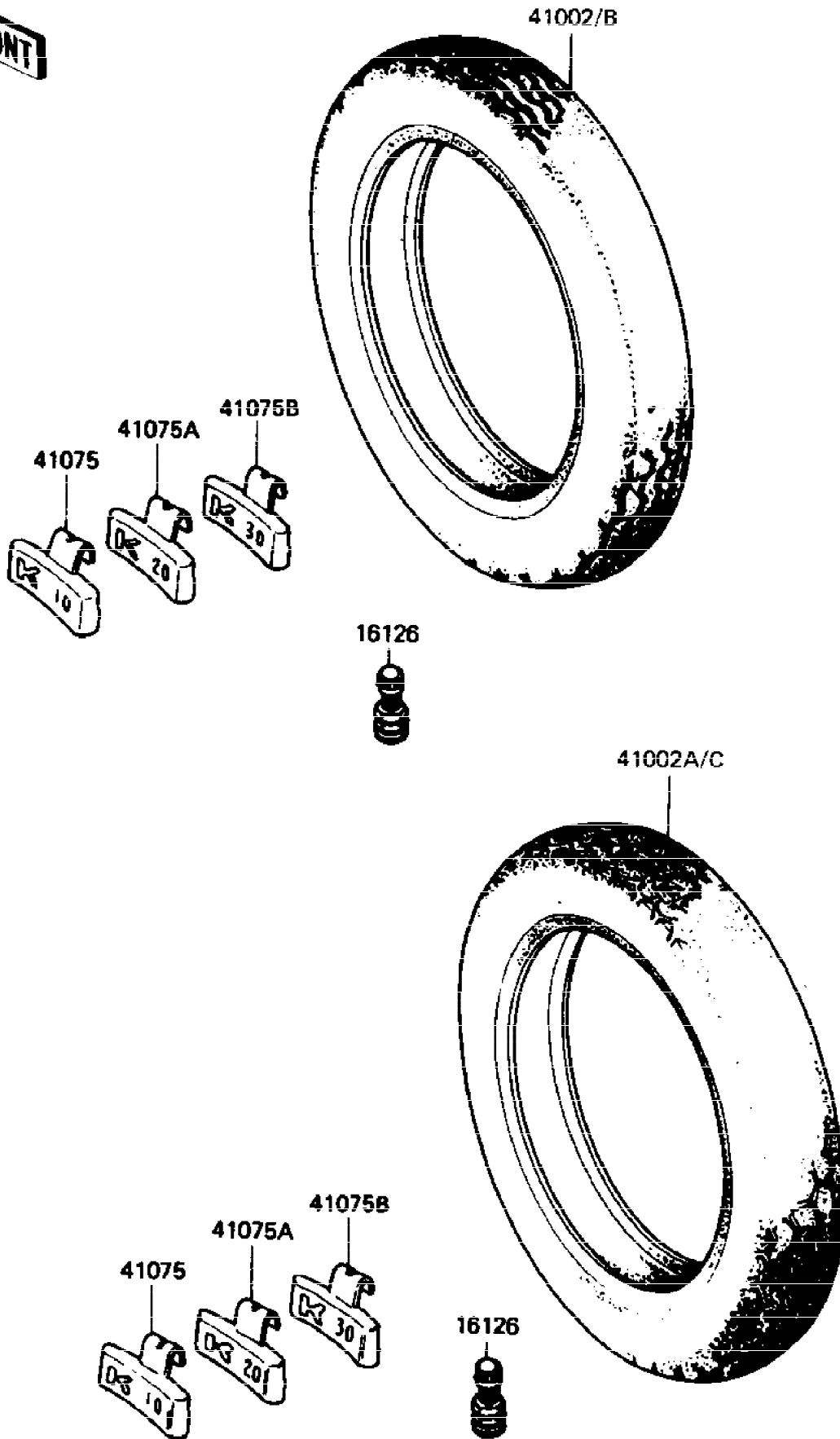

Ref #	Part Number	Qty	Description
16126	16126-1136	2	VALVE
41002	41002-1136	1	TIRE 325V-19 L303A F
41002A	41002-1137	1	TIRE 425V-18 G506 R
41002B	41002-1311	1	TIRE 110/90V19 K300 F
41002C	41002-1251	1	TIRE 120/90V-18K300 R
41075	41075-1011	AR	BALANCER-WHEEL,10G
41075A	41075-1012	AR	BALANCER-WHEEL,20G
41075B	41075-1013	AR	BALANCER-WHEEL,30G



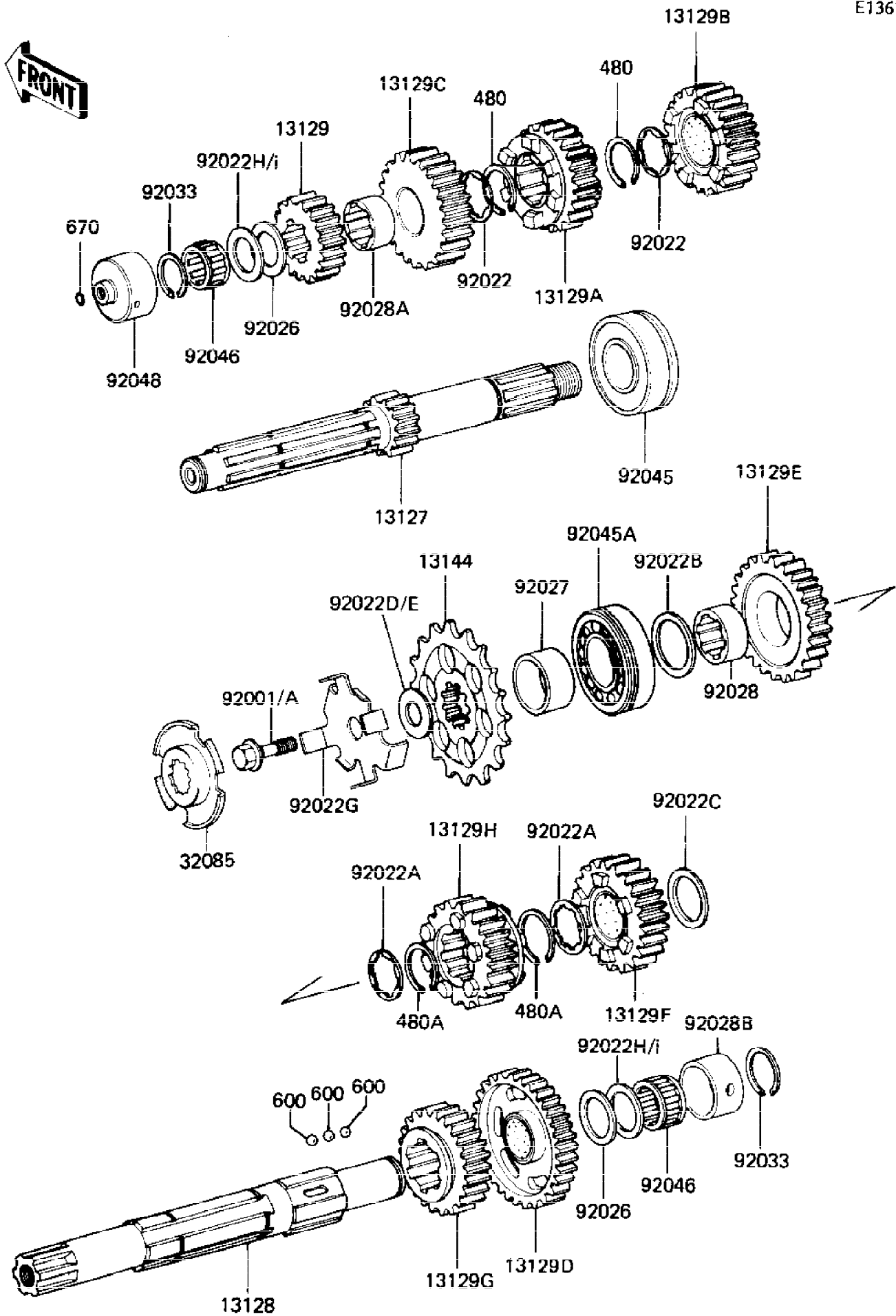

Ref #	Part Number	Qty	Description
13127	13127-1034	1	SHAFT-TRANSMISSION IN
13128	13128-1030	1	SHAFT-TRANSMISSION OU
13129	13129-1235	1	INPUT 2ND,18T
13129A	13129-1236	1	INPUT 3RD,21T
13129B	13129-1237	1	INPUT 4TH,23T
13129C	13129-1238	1	INPUT TOP,25T
13129D	13129-1239	1	OUTPUT LOW,37T
13129E	13129-1240	1	OUTPUT 2ND,33T
13129F	13129-1241	1	OUTPUT 3RD,30T
13129G	13129-1242	1	OUTPUT 4TH,27T
13129H	13129-1243	1	OUTPUT TOP,26T
13144	13144-1042	1	SPROCKET-OUTPUT,15T
32085	32085-1101	1	STOPPER,ENGN SPROCKET
92001	92001-5003	1	BOLT,FLANGED,10X35 ( - KZT10BE002967)
92001A	92001-1479	1	BOLT,FLANGED,10X39 ( KZT10BE002968 - )
92022	92022-1077	2	WASHER,LOCK (O.D=35)
92022A	92022-1218	2	WASHER,LOCK,30X42X1.4
92022B	92022-1219	1	WASHER,28.3X42X2.9
92022C	92022-1220	1	WASHER,32.3X42X3
92022D	92022-1247	1	WASHER ( - KZT10BE002967)
92022E	92022-1274	1	WASHER,12.3X38X2.3 ( KZT10BE002968 - )
92022G	92022-1351	1	WASHER,SPRCKT STOPPER
92022H	92022-212	2	WASHER,PLAIN,22MM
92022I	92022-213	AR	WASHER,PLAIN,22MM
92026	92026-1020	2	SPACER (I.D=22 O.D=35
92027	92027-1339	1	COLLAR
92028	92028-1112	1	BUSHING,2ND GEAR
92028A	92028-1124	1	BUSHING,TOP GEAR
92028B	92028-123	1	BUSH,OUTPUT SHAFT
92033	92033-025	2	CIRCLIP,25MM
92045	92045-1028	1	BEARING,BALL,5305NSH2
92045A	92045-1034	1	BEARING-BALL,63/28NC3
92046	92046-031	2	BEARING,PK223013.8
92048	92048-1012	1	RACE,DRIVE SHAFT BRNG
92048	92048-1012	4	RACE,DRIVE SHAFT BRNG
480	480J2800	2	CIRCLIP 28MM
480A	480J3200	2	CIRCRIP-TYPE-C
600	600A0600	3	BALL STEEL 3/16'
670	670B1508	1	"O" RING,8MM

F2730-0075

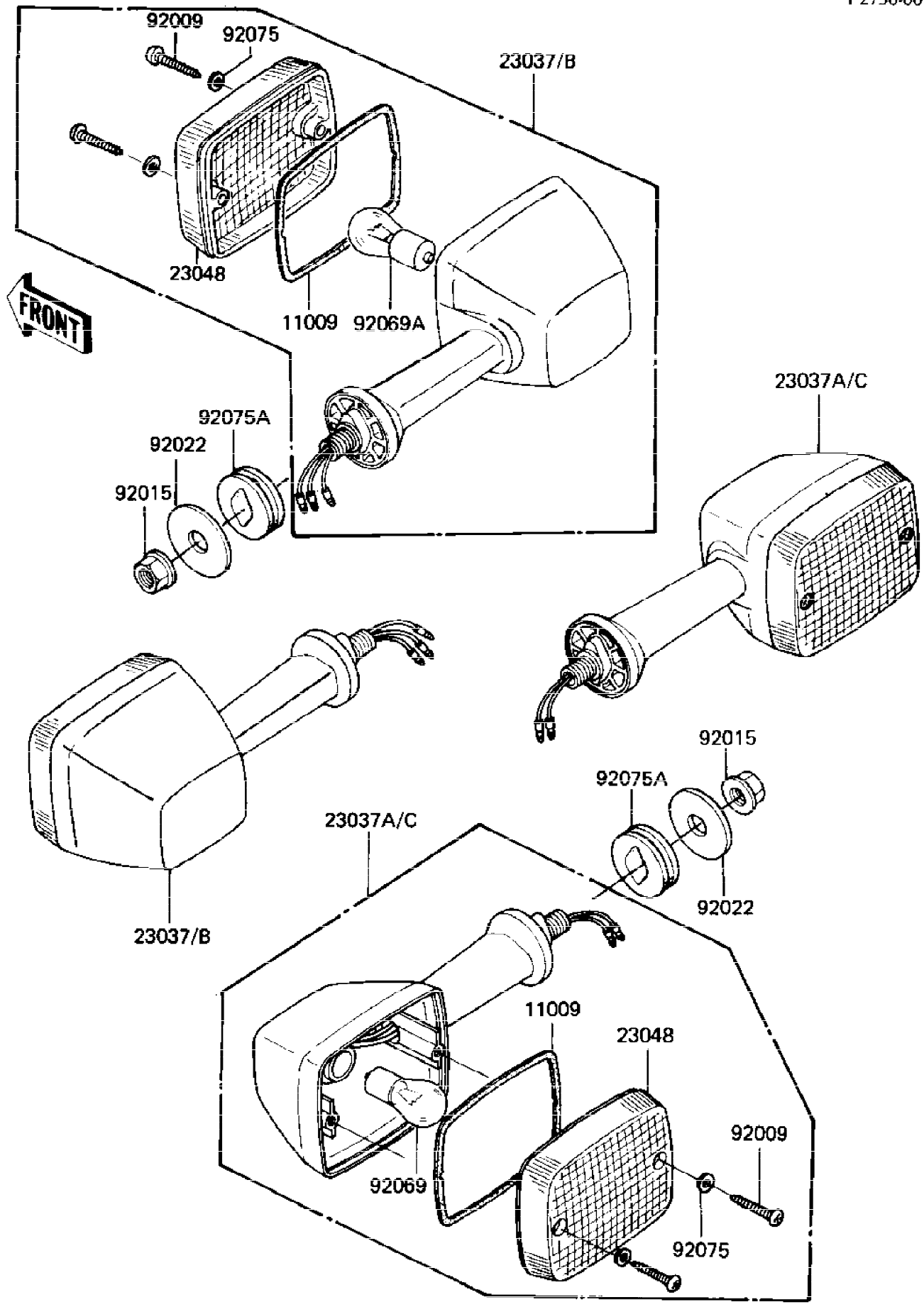

Ref #	Part Number	Qty	Description
11009	11009-1150	4	GASKET,SIGNAL LAMP
23037	23037-1131	2	LAMP-ASSY-SIGNAL,FR
23037A	23037-1104	2	LAMP-ASSY-SIGNAL
23037B	23037-1131	2	LAMP-ASSY-SIGNAL,FR
23037C	23037-1104	2	LAMP-ASSY-SIGNAL
23048	23048-1019	4	LENS-SIGNAL LAMP
92009	92009-1069	8	SCREW,TAPPING,4X25
92015	92015-1428	4	NUT,FLANGED,10MM
92022	92022-1246	4	WASHER,10.5X37X1.6
92069	92069-055	2	BULB 12V 32CP
92069A	92069-060	2	BULB,12V 23/8W
92075	23058-002	8	WASHER-PLAIN,4MM
92075A	92075-1391	4	DAMPER,SIGNAL LAMP

E1210-0005

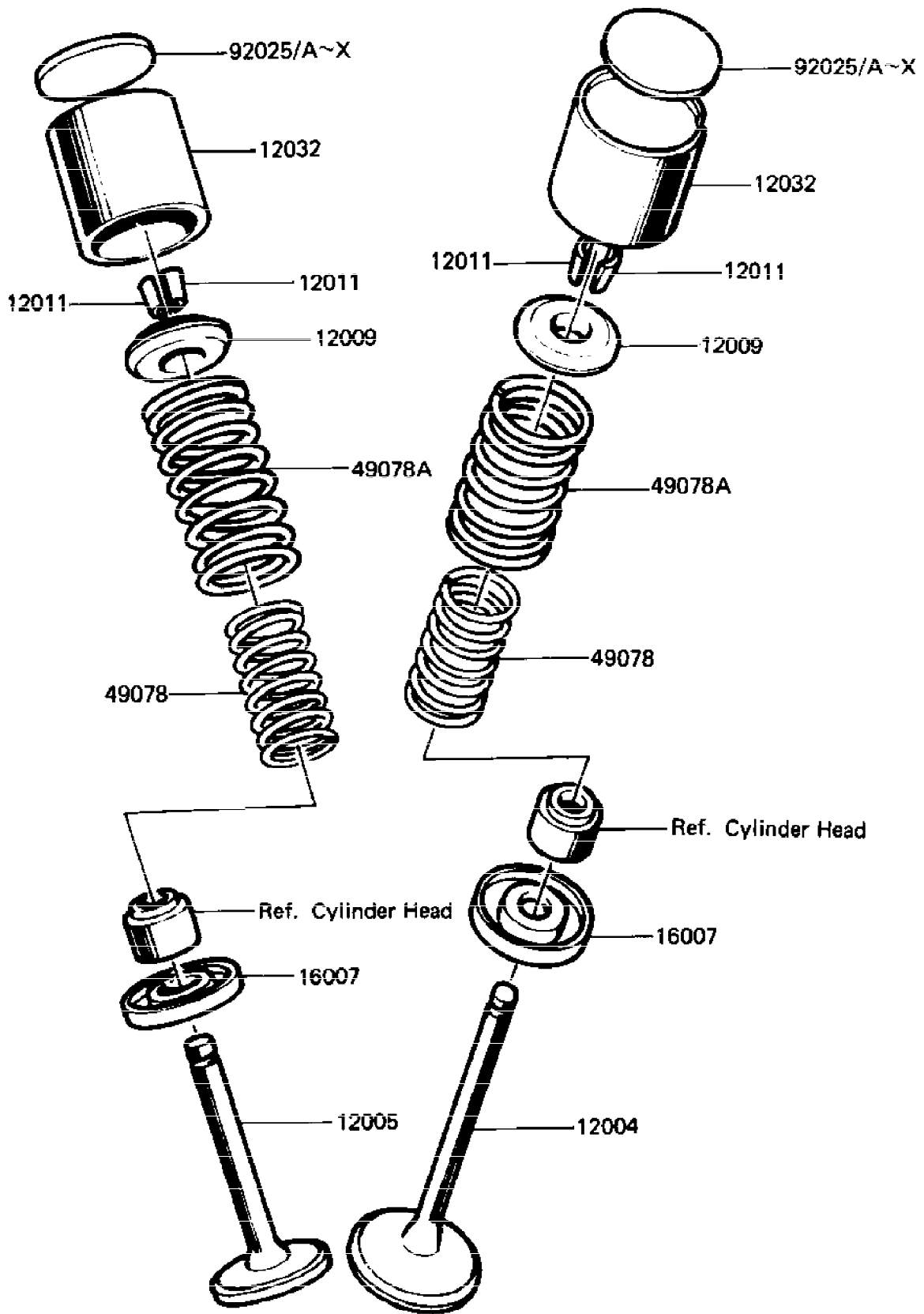

Ref #	Part Number	Qty	Description
12004	12004-1013	4	VALVE INTAKE
12005	12005-1011	4	VALVE EXHAUST
12009	12009-005	8	RETAINER,VALVE SPRING
12011	12011-004	16	SPLIT KEEPER
12032	12032-1002	8	TAPPET
16007	16007-1024	8	SEAT-SPRING,VALVE
49078	49078-1001	8	SPRING,VALVE,INNER
49078A	49078-1002	8	SPRING,VALVE,OUTER
92025	12037-001	AR	SHIM,TAPPET,2.00T
92025A	12037-002	AR	SHIM,TAPPET,2.05T
92025B	12037-003	AR	SHIM,TAPPET,2.10T
92025C	12037-004	AR	SHIM,TAPPET,2.15T
92025D	12037-005	AR	SHIM,TAPPET,2.20T
92025E	12037-006	AR	SHIM,TAPPET,2.25T
92025F	12037-007	AR	SHIM,TAPPET,2.30T
92025G	12037-008	AR	SHIM,TAPPET,2.35T
92025H	12037-009	AR	SHIM,TAPPET,2.40T
92025I	12037-010	AR	SHIM,TAPPET,2.45T
92025J	12037-011	AR	SHIM,TAPPET,2.50T
92025K	12037-012	AR	SHIM,TAPPET,2.55T
92025L	12037-013	AR	SHIM,TAPPET,2.60T
92025M	12037-014	AR	SHIM,TAPPET,2.65T
92025N	12037-015	AR	SHIM,TAPPET,2.70T
92025O	12037-016	AR	SHIM,TAPPET,2.75T
92025P	12037-017	AR	SHIM,TAPPET,2.80T
92025Q	12037-018	AR	SHIM,TAPPET,2.85T
92025R	12037-019	AR	SHIM,TAPPET,2.90T
92025S	12037-020	AR	SHIM,TAPPET,2.95T
92025T	12037-021	AR	SHIM,TAPPET,3.00T
92025U	12037-022	AR	SHIM,TAPPET,3.05T
92025V	12037-023	AR	SHIM,TAPPET,3.10T
92025W	12037-024	AR	SHIM,TAPPET,3.15T
92025X	12037-025	AR	SHIM,TAPPET 3.20T